

## ***GLOSSARY OF TERMS***

**Automotive Repair Shop:** a facility that is categorized in any one of the following Standard Industrial Classification (SIC) codes: 5013, 5014, 5541, 5511, 7532-7534, or 7536- 7539.

**Backfill:** Earth or engineered material used to refill a trench or an excavation.

**Berm:** An earthen mound used to direct the flow of runoff around or through a structure.

**Best Management Practices (BMPs):** methods, measures, or practices designed and selected to reduce or eliminate the discharge of pollutants to surface waters from point and nonpoint source discharges including storm water. BMPs include structural and nonstructural controls, and operation and maintenance procedures, which can be applied before, during, and/or after pollution producing activities.

**Buffer Strip or Zone:** Strip of erosion-resistant vegetation over which stormwater runoff is directed.

**Catch Basin (also known as Inlet or Drain Inlet):** Box-like underground concrete structure with openings in curbs and gutters designed to collect runoff from streets and pavements.

**Clean Water Act (CWA):** (33 U.S.C. 1251 et seq.) requirement of the NPDES program are defined under Sections 301, 307, 402, 318 and 405 of the CWA.

**Commercial Development:** Any development on private land that is not heavy industrial or residential. The category includes, but is not limited to hospitals, laboratories and other medical facilities, educational institutions, recreational facilities, plant nurseries, car wash facilities, mini-malls, business complexes, shopping malls, hotels, office buildings, public warehouses, and light industrial complexes.

**Conduit:** Any channel or pipe for directing the flow of water.

**Construction Activity:** Includes clearing, grading, excavation, and contractor activities that result in soil disturbance.

**Construction General Permit:** An NPDES permit issued by the SWRCB for the discharge of stormwater associated with construction activity from soil disturbance of five (5) acres or more. Threshold lowered to one acre beginning October 10, 2003 (Construction General Permit No. CAS000002).

**Conventional Treatment Controls:** A subset of Treatment Controls that can be designed to treat the SQDV/SQDF. These controls typically do not reduce runoff volumes and cannot be used to help meet the Volume Reduction Requirement.

**Conveyance System:** Any channel or pipe for collecting and directing the stormwater.

**Culvert:** A covered channel or a large diameter pipe that crosses under a road, sidewalk, etc.

**Dead-end Sump:** A below surface collection chamber for small drainage areas that is not connected to the public storm drainage system. Accumulated water in the chamber must be pumped and disposed in accordance with all applicable laws.

**Denuded:** Land stripped of vegetation or land that has had its vegetation worn down due to the impacts from the elements or humans.

**Designated Public Access Points:** Any pedestrian, bicycle, equestrian, or vehicular point of access to jurisdictional channels in the area subject to permit requirements.

**Detention:** The temporary storage of stormwater runoff to allow treatment by sedimentation and metered discharge of runoff at reduced peak flow rates. The capture and subsequent release of stormwater runoff from the site at a slower rate than it is collected the difference being held in temporary storage.

**Development:** Any construction, rehabilitation, redevelopment or reconstruction of any public or private residential project (whether single-family, multi-unit or planned unit development); industrial, commercial, retail and other non-residential projects, including public agency projects; or mass grading for future construction. It does not include routine maintenance to maintain original line and grade, hydraulic capacity, or original purpose of facility, nor does it include emergency construction activities required to immediately protect public health and safety.

**Directly Adjacent:** Situated within 200 feet of the contiguous zone required for the continued maintenance, function, and structural stability of an environmentally sensitive area.

**Directly Connected Impervious Area (DCIA):** The area covered by a building, impermeable pavement, and/or other impervious surfaces, which drains directly into the storm drain without first flowing across permeable land area (e.g. turf buffers, grass-lined channels).

**Directly Discharging:** Outflow from a drainage conveyance system that is composed entirely or predominantly of flows from the subject, property, development, subdivision, or industrial facility, and not commingled with the flows from adjacent lands.

**Discharge of a Pollutant:** any addition of any pollutant or combination of pollutants to waters of the United States from any point source or, any addition of any pollutant or combination of pollutants to the waters of the contiguous zone or the ocean from any point source other than a vessel or other floating craft which is being used as a means of transportation. The term discharge includes additions of pollutants into waters of the United States from: surface runoff which is collected or channeled by man; discharges through pipes, sewers, or other conveyances owned by a State, municipality, or other person which do not lead to a treatment works; and discharges through pipes, sewers, or other conveyances, leading into privately owned treatment works.

**Disturbed Area:** Area that is altered as a result of clearing, grading, and/or excavation.

**Effluent Limits:** Limitations on amounts of pollutants that may be contained in a discharge. Can be expressed in a number of ways including as a concentration, as a concentration over a time period (e.g., 30-day average must be less than 20 mg/L), or as a total mass per time unit, or as a narrative limit.

**Erosion:** The wearing away of land surface by wind or water. Erosion occurs naturally from weather or runoff but can be intensified by land-clearing practices relating to farming, residential or industrial development, road building, or timber cutting.

**Excavation:** The process of removing earth, stone, or other materials, usually by digging.

**Filter Fabric:** Geotextile of relatively small mesh or pore size that is used to: (a) allow water to pass through while keeping sediment out (permeable); or (b) prevent both runoff and sediment from passing through (impermeable).

**Grading:** The cutting and/or filling of the land surface to a desired shape or elevation.

**Hazardous Substance:** (1) Any material that poses a threat to human health and/or the environment. Typical hazardous substances are toxic, corrosive, ignitable, explosive, or chemically reactive; (2) Any substance named by EPA to be reported if a designated quantity of the substance is spilled in the waters of the United States or if otherwise emitted into the environment.

**Hazardous Waste:** A waste or combination of wastes that, because of its quantity, concentration, or physical chemical, or infectious characteristics, may either cause or significantly contribute to an increase in mortality or an increase in serious irreversible illness; or pose a substantial present or potential hazard to human health or the environment when improperly treated, stored, transported, disposed of, or otherwise managed. Possesses at least one of four characteristics (ignitability, corrosivity, reactivity, or toxicity) or appears on special EPA or state lists. Regulated under the federal Resource Conservation and Recovery Act and the California Health and Safety Code.

**Hydromodification:** The change in the natural watershed hydrologic processes and runoff characteristics (i.e., interception, infiltration, overland flow, interflow and groundwater flow) caused by urbanization or other land use changes that result in increased stream flows and sediment transport. In addition, alteration of stream and river channels, installation of dams and water impoundments, and excessive stream bank and shoreline erosion are also considered hydromodification, due to their disruption of natural watershed hydrologic processes.

**Illicit Connection:** Any man-made conveyance that is connected to the storm drain system without a permit, excluding roof drains and other similar type connections. Examples include channels, pipelines, conduits, inlets, or outlets that are connected directly to the storm drain system.

**Illicit Discharge:** Any discharge to the storm drain system that is prohibited under local, state, or federal statutes, ordinances, codes, or regulations. The term “illicit discharge” includes all non storm-water discharges except discharges pursuant to an NPDES permit, discharges that are identified in Discharge Prohibitions of this Order, and discharges authorized by the Regional Board.

**Impervious Surface/ Cover:** A hard surface area that impede the natural infiltration of stormwater and causes water to runoff the surface in greater quantities or at an increased rate of flow from the flow present under pre-project conditions. Impervious surfaces include, but are not limited to, rooftops, walkways, patios, driveways, parking lots, roads or concrete and asphalt paving.

**Industrial General Permit:** An NPDES Permit (No. CAS000001) issued by the SWRCB for the discharge of Stormwater associated with industrial activity. Board Order 97-03-DWQ.

**Infiltration:** The downward entry of water into the surface of the soil.

**Inlet:** An entrance into a ditch, storm sewer, or other waterway.

**Integrated Pest Management (IPM):** An ecosystem-based strategy that focuses on long-term prevention of pests or their damage through a combination of techniques such as biological control, habitat manipulation, modification of cultural practices, and use of resistant varieties. Pesticides are used only after monitoring indicates they are needed according to established guidelines, and treatments are made with the goal of removing only the target organism.

**Low Impact Development (LID):** A stormwater management and land development strategy that emphasizes conservation and the use of on-site natural features integrated with engineered, small-scale hydrologic controls to more closely reflect pre-development hydrologic functions.

**LID Treatment Controls:** A subset of Treatment Controls that can be designed to treat the SQDV/SQDF and reduce runoff volumes. The runoff reduction achieved by these controls can be used to help meet the Volume Reduction Requirement.

**Material Storage Areas:** On site locations where raw materials, products, final products, by-products, or waste materials are stored.

**Municipal Separate Storm Sewer System (MS4):** a conveyance or system of conveyances (including roads with drainage systems, municipal streets, alleys, catch basins, curbs, gutters, ditches, manmade channels, or storm drains) owned by a State, city, county, town or other public body, that is designed or used for collecting or conveying storm water, which is not a combined sewer, and which is not part of a publicly owned treatment works, and which discharges to Waters of the United States.

**National Pollutant Discharge Elimination System (NPDES):** The national program for issuing, modifying, revoking and reissuing, terminating, monitoring and enforcing permits, and imposing and enforcing pretreatment requirements, under CWA §307, 402, 318, and 405.

**New Development:** Land disturbing activities; structural development, including construction or installation of a building or structure, creation of impervious surfaces; and land subdivision.

**Non-Stormwater Discharge:** Any discharge to municipal separate storm drain that is not composed entirely of stormwater. Discharges containing process wastewater, non-contact cooling water, or sanitary wastewater are non-stormwater discharges.

**Nonpoint Source Pollution:** Pollution that does not come from a point source. Nonpoint source pollution originates from diffuse sources that are mostly related to land use.

**Non-Structural Best Management Practice (BMP):** Low technology procedures or management practices designed to prevent pollutants associated with site functions and activities from being discharged with stormwater runoff. Examples include reducing impervious cover, rain barrels, good housekeeping practices, employee training, standard operating practices, inventory control measures, etc.

**Notice of Intent (NOI):** A formal notice to SWRCB submitted by the owner/developer of an industrial or construction site that said owner seeks coverage under a General Permit for discharges associated with industrial and construction activities. The NOI provides information on the owner, location, type of project, and certifies that the owner will comply with the conditions of the construction General Permit.

**Notice of Termination (NOT):** Formal notice to the SWRCB submitted by owner/developer that a construction project is complete.

**Outfall:** The point where stormwater discharges from a pipe, channel, ditch, or other conveyance to a waterway. The end point where storm drains discharge water into a waterway.

**Parking Lot:** Land area or facility for the temporary parking or storage of motor vehicles used personally, for business or for commerce with an impervious surface area of 5,000 square feet or more, or with 25 or more parking spaces.

**Permeability:** A property of soil that enables water or air to move through it. Usually expressed in inches/hour or inches/day.

**Point Source:** Any discernible, confined, and discrete conveyance from which pollutants are or may be discharged. This term does not include return flows from irrigated agriculture or agricultural stormwater runoff.

**Pollutant:** A substance introduced into the environment that adversely affects the usefulness of a resource.

**Pollution Prevention (P2):** Practices and actions that reduce or eliminate the generation of pollutants.

**Post-project:** The land use condition as a result of the proposed development activity.

**Precipitation:** Any form of rain or snow.

**Pre-project:** The existing land use condition prior to the proposed development activity.

**Receiving Stream:** (for purposes of this Manual only) any natural or man-made surface water body that receives and conveys stormwater runoff.

**Reclamation or Recycling (water reclamation or recycling):** Planned use of treated effluent that would otherwise be discharged without being put to direct use.

**Redevelopment:** Land-disturbing activity that results in the creation, addition, or replacement of 5,000 square feet or more of impervious surface area on an already developed site. Redevelopment includes, but is not limited to: the expansion of a building footprint; addition or replacement of a structure; replacement of impervious surface area that is not part of a routine maintenance activity; and land disturbing activities related to structural or impervious surfaces. It does not include routine maintenance to maintain original line and grade, hydraulic capacity, or original purpose of facility, nor does it include emergency construction activities required to immediately protect public health and safety.

**Regional stormwater management facilities:** A regional stormwater management facility is defined as a facility that provides detention of stormwater runoff typically for the entire upstream watershed.

**Restaurant:** means a facility that sells prepared foods and drinks for consumption, including stationary lunch counters and refreshment stands selling prepared foods and drinks for immediate consumption (SIC Code 5812).

**Retail Gasoline Outlet:** Any facility engaged in selling gasoline and lubricating oils.

**Retention:** The storage of stormwater to prevent it from leaving the development site; may be temporary or permanent.

**Runoff:** Water originating from rainfall, melted snow, and other sources (e.g., sprinkler irrigation) that flows over the land surface to drainage facilities, rivers, streams, springs, seeps, ponds, lakes, wetlands, and shallow groundwater.

**Run-on:** Stormwater surface flow or other surface flow which enters property or area other than that where it originated. Off site stormwater surface flow or other surface flow which enters the site.

**Scour:** The erosive and digging action in a watercourse caused by flowing water.

**Secondary Containment:** Structures, usually dikes or berms, surrounding tanks or other storage containers and designed to catch spilled material from the storage containers.

**Sedimentation:** The process of depositing soil particles, clays, sands, or other sediments that were picked up by runoff.

**Sediments:** Soil, sand, and minerals washed from land into water, usually after rain, that accumulate in reservoirs, rivers, and harbors, destroying aquatic animal habitat and clouding the water such that adequate sunlight might not reach aquatic plants. Farming, mining, and building activities without proper implementation of BMPs will expose sediment materials, allowing them to be washed off the land after rainfalls.

**Significant Materials:** Includes, but not limited to, raw materials; fuels; materials such as solvents, detergents, and plastic pellets; finished materials such as metallic products; raw materials used in food processing or production; hazardous substances designed under Section 101(14) of CERCLA; any chemical the facility is required to report pursuant of Section 313 of Title III of SARA; fertilizers; pesticides; and waste products such as ashes, slag, and sludge that have the potential to be released with stormwater discharges.

**Significant Quantities:** The volume, concentrations, or mass of a pollutant in stormwater discharge that can cause or threaten to cause pollution, contamination, or nuisance that adversely impact human health or the environment and cause or contribute to a violation of any applicable water quality standards for receiving water.

**Source Control BMPs:** Any schedules of activities, structural devices, prohibitions of practices, maintenance procedures, managerial practices or operational practices that aim to prevent stormwater pollution by reducing the potential for contamination at the source of pollution.

**Source Reduction (also Source Control):** The technique of stopping and/or reducing pollutants at their point of generation so that they do not come into contact with stormwater.

**Spill Guard:** A device used to prevent spills of liquid materials from storage containers.

**Spill Prevention Control and Countermeasures Plan (SPCC):** Plan consisting of structures, such as curbing, and action plans to prevent and respond to spills of hazardous substances as defined in the CWA.

**Storm Drains:** Above- and below-ground structures for transporting stormwater to streams or outfalls for flood control purposes.

**Storm Drain System:** Network of above and below-ground structures for transporting stormwater to streams or outfalls.

**Storm Event:** A rainfall event that produces more than 0.1 inch of precipitation and is separated from the previous storm event by at least 72 hours of dry weather.

**Stormwater:** Stormwater runoff, snow-melt runoff, surface runoff, and drainage, excluding infiltration and irrigation tailwater. Urban runoff and snowmelt runoff consisting only of those discharges, which originate from precipitation events. Stormwater is that portion of precipitation that flows across a surface to the storm drain system or receiving waters.

**Stormwater Discharge Associated with Industrial Activity:** Discharge from any conveyance which is used for collecting and conveying stormwater which is related to manufacturing processing or raw materials storage areas at an industrial plant [see 40 CFR 122.26(b)(14)].

**Stormwater Pollution Prevention Plan (SWPPP):** A written plan that documents the series of phases and activities that, first, characterizes your site, and then prompts you to select and carry out actions which prevent the pollution of stormwater discharges.

**Structural BMP:** Any structural facility designed and constructed to mitigate the adverse impacts of stormwater and urban runoff pollution (e.g. canopy, structural enclosure). The category may include both Treatment Control BMPs and Source Control BMPs.

**Treatment Controls:** Any engineered system designed to remove pollutants by simple gravity settling of particulate pollutants, filtration, biological uptake, media adsorption or any other physical, biological, or chemical process. Treatment Controls, for the purposes of this Plan have been divided into two types: LID Treatment Controls and Conventional Treatment Controls.

**Treatment:** The application of engineered systems that use physical, chemical, or biological processes to remove pollutants. Such processes include, but are not limited to, filtration, gravity settling, media adsorption, biodegradation, biological uptake, chemical oxidation and ultraviolet radiation.

**Toxicity:** Adverse responses of organisms to chemicals or physical agents ranging from mortality to physiological responses such as impaired reproduction or growth anomalies.

**Turbidity:** Describes the ability of light to pass through water. The cloudy appearance of water caused by suspended and colloidal matter (particles).

**Volume Reduction Measures:** BMPs that can be used to direct, retain, reuse and/or infiltrate stormwater runoff (e.g., rain gardens and rain barrels).

**Volume Reduction Requirement:** New Development Priority Projects must reduce post-project runoff volume to pre-project runoff volumes for the 0.51” rainfall event (~85th percentile) using a combination of Volume Reduction Measures and LID Treatment Controls.

## ***LIST OF ACRONYMS***

AASHTO	American Association of State Highway and Transportation Officials
AC	Asphalt Concrete
ANSI	American National Standards Institute
APHA	American Public Health Association
APWA	American Public Works Association
ASTM	American Society for Testing Materials
AWWA	American Water Works Association
BAT	Best Available Technology (economically achievable)
BCT	Best Conventional Technology (pollution control)
BMPs	Best Management Practices
BOD	Biochemical Oxygen Demand
CAL-EPA	California Environmental Protection Agency
CAL-OSHA	California Division of Occupational Safety and Health Administration
CASQA	California Stormwater Quality Association
CCR	California Code of Regulations
CEQA	California Environmental Quality Act
CFR	Code of Federal Regulations
COE	U.S. Army Corps of Engineers
CWA	Clean Water Act (Federal Water Pollution Control Act of 1972 as amended in 1987)
DCIA	Directly Connected Impervious Area
DTSC	California Department of Toxic Substances Control
EIR	Environmental Impact Report
EMC	Event Mean Concentration
EPA	United State Environmental Protection Agency
ESA	Environmentally Sensitive Area
ESC	Erosion and Sediment Control
FHWA	Federal Highway Administration
GIS	Geographical Information System
Hazmat	Hazardous Material
HSG	Hydrologic Soil Groups
IPM	Integrated Pest Management
LID	Low Impact Development
MEP	Maximum Extent Practicable
MS4	Municipal Separate Storm Sewer System
MSDS	Material Safety Data Sheet

NOI	Notice of Intent
NPDES	National Pollutant Discharge Elimination System
NPS	Nonpoint Source
NRCS	Natural Resources Conservation Service
NSF	National Science Foundation
O&G	Oil and Grease
O&M	Operations and Maintenance
OSHA	Occupational Safety and Health Administration
PAHs	Polyaromatic Hydrocarbons
PCBs	Polychlorinated Biphenyls
PCC	Portland Cement Concrete
PPT	Pollution Prevention Team
POTW	Publicly Owned Treatment Works
PSD	Particle Size Distribution
RCRA	Resource Conservation and Recovery Act
RGO	Retail Gasoline Outlet
RWQCB	Regional Water Quality Control Board
SAP	Sampling and Analysis Plan
SIC	Standard Industrial Classification
SPCC	Spill Prevention Control and Countermeasure
SQDF	Stormwater Quality Design Flow
SQDV	Stormwater Quality Design Volume
SWPCP	Stormwater Pollution Control Plan
SWPPP	Stormwater Pollution Prevention Plan
SWQCCP	Stormwater Quality Control Criteria Plan
SWQCP	Stormwater Quality Control Plan
SWRCB	State Water Resources Control Board
TMDL	Total Maximum Daily Load
TOC	Total Organic Carbon
TSS	Total Suspended Solids
UFC	Uniform Fire Code
USACE	United States Army Corps of Engineers
USDA	United States Department of Agriculture
USDOT	United States Department of Transportation
USEPA	United States Environmental Protection Agency
WEF	Water Environment Federation

**THIS PAGE INTENTIONALLY LEFT BLANK**

## Volume Reduction Requirement Summary Worksheet

<b>Project:</b> _____ <b>Detail:</b> _____ <b>Design by:</b> _____ <b>Date:</b> _____	
1. Project Drainage Area Characteristics: Pre-project a. Weighted Runoff Coefficient ( $C_{rPRE}$ ) b. Total Drainage Area ( $A_{PRE}$ ) c. Pre-project Runoff Volume ( $Vol_{PRE}$ )* $Vol_{PRE} = (0.51/12) \times A_{PRE} \times C_{rPRE}$	$C_{rPRE} =$ _____ $A_{PRE} =$ _____ $ft^2$ $Vol_{PRE} =$ _____ $ft^3$
2. Project Drainage Area Characteristics: Post-project a. Weighted Runoff Coefficient ( $C_{ra}$ ) b. Total Drainage Area ( $A_{POST}$ ) c. Post-project Runoff Volume ( $Vol_{POST}$ ) $Vol_{POST} = (0.51/12) \times A_{POST} \times C_{ra}$ d. Volume Reduction Requirement (VRR)* <b><math>VRR = Vol_{POST} - Vol_{PRE}</math></b>	$C_{ra} =$ _____ $A_{POST} =$ _____ $ft^2$ $Vol_{POST} =$ _____ $ft^3$ <b><math>VRR =</math> _____ <math>ft^3</math></b>
3. Volume Reduction Measures (VRMs): a. Total number of VRMs in project b. Total Volume Reduction Credits from VRMs ( $\sum Vol_{VRM}$ ) c. Total Tributary Impervious Area Reduction Credits for application to effective area calculation ( $\sum Area_{credit}$ ) d. Remaining Volume Reduction required from LID Treatment Controls ( $VRR_{TREAT}$ ) $VRR_{TREAT} = VRR - \sum Vol_{VRM}$	No. VRMs = _____ $\sum Vol_{VRM} =$ _____ $ft^3$ $\sum Area_{credit} =$ _____ $ft^2$ <b><math>VRR_{TREAT} =</math> _____ <math>ft^3</math></b>
4. LID Treatment Controls – Volume Reduction Credits a. Total Volume Reduction Credits from LID Treatment Controls ( $\sum Vol_{TREAT}$ ) b. Total Volume Reduction Provided ( $VRR_{PROVIDED}$ ) $VRR_{PROVIDED} = \sum Vol_{VRM} \text{ (line 3b)} + \sum Vol_{TREAT} \text{ (line 4a)}$ c. Volume Reduction remaining ( $VRR_{REMAIN}$ ) $VRR_{REMAIN} = VRR - VRR_{PROVIDED}$	$\sum Vol_{TREAT} =$ _____ $ft^3$ $VRR_{PROVIDED} =$ _____ $ft^3$ <b><math>VRR_{REMAIN} =</math> _____ <math>ft^3</math></b>
<p>Note: If <math>VRR_{REMAIN} &gt; 0</math>, the Volume Reduction Requirement is not fully met. Meeting the Volume Reduction Requirement may be iterative for most sites - designers should return to prior steps to explore alternative combinations of Volume Reduction Measures and LID Treatment Controls. If the meeting the full Volume Reduction Requirement is infeasible, a Volume Reduction Requirement Waiver Application must be submitted (see Section 5-2 and Appendix C).</p>	

\*Apply reductions to Volume Reduction Requirement as appropriate for Significant Redevelopment as described in Section 5.

**THIS PAGE INTENTIONALLY LEFT BLANK**

---

## ***Volume Reduction Requirement Waiver Application***

---

A waiver may be granted if the Volume Reduction Requirement cannot be met due to site constraints, such as a high groundwater table. However, even if the project cannot meet the full Volume Reduction Requirement, the project must still reduce volume to the maximum extent practicable. The burden of proof is on the project applicant to show why the full Volume Reduction Requirement cannot be met. Economic hardship is not an acceptable reason for noncompliance. In general, the City and County do not expect to grant waivers for the Volume Reduction Requirement.

Meeting the Volume Reduction Requirement is an iterative process. Designers should return to prior steps to explore alternative combinations of Volume Reduction Measures and LID Treatment Controls. Projects that cannot fully meet the Volume Reduction Requirement and are located in a watershed with a 303d listed waterbody, must select Treatment Controls with a medium to high removal efficiency for the pollutant of concern (see Table 6-2).

The final determination will be made by City of Stockton Department of Municipal Utilities, Technical Services Division or the San Joaquin County Department of Public Works, Community Infrastructure Division. The City and County have the authority to reject a Volume Reduction Requirement Waiver request if Volume Reduction Measures and/or LID Treatment Controls are considered feasible at the project site.

Consideration of a waiver request requires applicants to:

- Reduce volume to the maximum extent practicable, even if the full Volume Reduction Requirement cannot be met.
- Consider all of the Volume Reduction Measures and LID Treatment Controls. Applicants must show why certain Volume Reduction Measures and/or LID Treatment Controls are not feasible at the development site.
- Submit this application with or prior to preliminary site plan submission.
- Obtain the signature and stamp of the project engineer registered in California.
- Submit the Volume Reduction Design Summary Worksheet (Appendix B) along with this application.

**1. Project Name**

**2. Project Category**

(See Section 2 for categories)

**3. Property Description**

(include location, size, land uses, etc.)

**4. Owner/Developer's Name**

Address

Phone

**5. Plan Preparer's Name**

Address

Phone

**6. Volume Reduction**

Volume Reduction Requirement  
(Volume Reduction Summary Worksheet, line 2e)

Volume Reduction Provided  
(Volume Reduction Summary Worksheet, line 4b)

Volume Reduction Remaining  
(Volume Reduction Summary Worksheet, line 4c)

Type and Number of Volume  
Reduction Measures Proposed:

- Rain Garden (V-1)
- Rain Barrel/Cistern (V-2)
- Vegetated Roof (V-3)
- Interception Trees (V-4)
- Grassy Channel (V-5)
- Vegetated Buffer Strip (V-6)

Type and Number of LID  
Treatment Controls Proposed:

- Bioretention (L-1)
- Stormwater Planter (L-2)
- Tree-well Filter (L-3)
- Infiltration Basin (L-4)
- Infiltration Trench/Dry Well (L-5)
- Porous Pavement Filter (L-6)
- Vegetated (Dry) Swale (L-7)
- Grassy Swale (L-8)
- Grassy Filter Strip (L-9)

**7. Describe Why a Volume Reduction Requirement Waiver is Needed**

(please include specifics regarding site constraints – e.g., results of any soil testing that may have been done)

**CERTIFICATION**

I hereby certify that the information provided in this Application is correct

Application Prepared By: \_\_\_\_\_  
Print Name and Firm

Signed \_\_\_\_\_  
(Signature of Project Engineer in the Firm Named Above)

Title \_\_\_\_\_  
(Affix professional registration stamp of the person named above with signature and expiration date)

**THIS PAGE INTENTIONALLY LEFT BLANK**

---

*Appendix D*

***Maintenance Agreements and Forms***

---

This appendix includes the following maintenance agreements and forms:

- D-1: Stormwater Treatment Device Access and Maintenance Agreement
- D-2: Owner's Certification Statement
- D-3: Sample Engineer's Report

---

*Appendix D-1*

***Stormwater Treatment Device Access and Maintenance Agreement***

---

**INSTRUCTIONS TO COMPLETE**

**STORMWATER TREATMENT DEVICE ACCESS  
AND MAINTENANCE AGREEMENT**

Please complete the following:

1. Complete the Stormwater Treatment Device Access and Maintenance Agreement (Agreement) with the owner(s) name, mailing address, property address, and assessor parcel number. Enter the date and owners names in the first paragraph. A copy of the Deed must be attached as the last page to verify the ownership and legal description. Complete the **owner acknowledgment** on page 5, and have it notarized.
2. Return one original signed copy of the Agreement to the Municipal Utilities Department, c/o John Wotila, 2500 Navy Drive, Stockton, CA 95206. A recording fee check payable to the San Joaquin County Recorder must be submitted with signed agreement upon filing with the City. The recording fee is currently \$8.00 for the first page and \$3.00 for each additional page. City staff will record the executed Agreement at the office of the San Joaquin County Recorder.
3. The City will provide one fully-executed copy of Agreement to the Owner for his/her record.

Should you have questions or require other assistance regarding this matter, please do not hesitate to contact John Wotila at (209) 937-8436 in the Permit Center.

**Stormwater Treatment Device  
Access and Maintenance  
Agreement**

After recorded, return to:  
Rebecca King  
City of Stockton  
Municipal Utilities Department  
2500 Navy Drive  
Stockton, CA 95206

---

**MUNICIPAL UTILITIES DEPARTMENT**  
After Recording Transmit Copy to:

\_\_\_ Owner of Record  
\_\_\_ Municipal Utilities Department  
\_\_\_ City Clerk (Original)

**OWNER NAME (S)  
(as shown on deed) &  
MAILING ADDRESS**

---

---

**O&M CONTACT  
PERSON & PHONE #**

---

---

**FACILITY NAME  
AND ADDRESS**

---

---

**ASSESSOR PARCEL NO.**

---

**THIS AGREEMENT** is made and entered into in \_\_\_\_\_, California,  
this \_\_\_\_ day of \_\_\_\_\_, by and between \_\_\_\_\_  
hereinafter referred to as "Owner" and the CITY OF STOCKTON, a municipal corporation,  
located in the County of San Joaquin, State of California hereinafter referred to as "CITY";

**WHEREAS**, the Owner owns real property ("Property") in the City of Stockton, County  
of San Joaquin, State of California, depicted in Exhibit "A" and intends to install a pollution  
control system described in Exhibit "B", both of which are attached hereto and incorporated  
herein by this reference;

**WHEREAS**, at the time of initial approval of development project known as \_\_\_\_\_ within the Property described herein, the City required the project to employ on-site control measures to minimize pollutants in urban runoff;

**WHEREAS**, the Owner has chosen to install a \_\_\_\_\_, hereinafter referred to as "Device", as the on-site control measure to minimize pollutants in urban runoff;

**WHEREAS**, said Device has been installed in accordance with the requirements of the City of Stockton Stormwater Quality Control Criteria Plan and the Owner's plans and specifications accepted by the City;

**WHEREAS**, said Device, with installation on private property and draining only private property, is a private facility with all operation, maintenance and replacement, therefore, the sole responsibility of the Owner in accordance with the terms of this Agreement;

**WHEREAS**, the Owner is aware that periodic and continuous maintenance, including, but not necessarily limited to, sediment removal, is required to assure peak performance of Device and that, furthermore, such maintenance activity will require compliance with all Local, State, or Federal laws and regulations, including those pertaining to confined space and waste disposal methods, in effect at the time such maintenance occurs;

**NOW THEREFORE**, it is mutually stipulated and agreed as follows:

1. Owner hereby provides the City or City's designee complete access, of any duration, to the Device and its immediate vicinity at any time, upon reasonable notice, or in the event of emergency, as determined by City's Director of Municipal Utilities with no advance notice, for the purpose of inspection, sampling, testing of the Device, and in case of emergency, to undertake all necessary repairs or other preventative measures at owner's expense as provided in paragraph 3 below. The Owner/Operator shall retain all operation and maintenance records at the facility for City inspection, and a copy shall be provided to the City if requested. City shall make every effort at all times to minimize or avoid interference with Owner's use of the Property.
2. Owner shall use its best efforts to diligently maintain the Device in a manner assuring peak performance at all times. All reasonable precautions shall be exercised by Owner and Owner's representative or contractor in the removal and extraction of material(s) from the Device and the ultimate disposal of the material(s) in a manner consistent with all relevant laws and regulations in effect at the time. When requested from time to time by the City, the Owner shall provide the City with documentation identifying the material(s) removed, the quantity, and disposal destination.
3. In the event Owner, or its successors or assigns, fails to accomplish the necessary maintenance contemplated by this Agreement, within five (5) days of being given written notice by the City, the City is hereby authorized to cause any maintenance necessary to be done and charge the entire cost and expense to the Owner or Owner's successors or assigns,

including administrative costs, attorneys fees and interest thereon at the maximum rate authorized by the Civil Code from the date of the notice of expense until paid in full, and Owner hereby agrees to pay such charge within 30 days of receipt of City's written demand for payment.

4. The City may require the owner to post security in form and for a time period satisfactory to the City of guarantee the performance of the obligations stated herein. Should the Owner fail to perform the obligations under the Agreement, the City may, in the case of a cash bond, act for the Owner using the proceeds from it, or in the case of a surety bond, require the sureties to perform the obligations of the Agreement. As an additional remedy, the Director may withdraw any previous stormwater related approval with respects to the property on which a Device has been installed until such time as Owner repays to City its reasonable costs incurred in accordance with paragraph 3 above.
5. This agreement shall be recorded in the Office of the Recorder of San Joaquin County, California, at the expense of the Owner and shall constitute notice to all successors and assigns of the title to said Property of the obligation herein set forth, and also a lien in such amount as will fully reimburse the City, including interest as herein above set forth, subject to foreclosure in event of default in payment.
6. In event of legal action occasioned by any default or action of the Owner, or its successors or assigns, then the Owner and its successors or assigns agree(s) to pay all costs incurred by the City in enforcing the terms of this Agreement, including reasonable attorney's fees and costs, and that the same shall become a part of the lien against said Property.
7. It is the intent of the parties hereto that burdens and benefits herein undertaken shall constitute covenants that run with said Property and constitute a lien there against.
8. The obligations herein undertaken shall be binding upon the heirs, successors, executors, administrators and assigns of the parties hereto. The term "Owner" shall include not only the present Owner, but also its heirs, successors, executors, administrators, and assigns. Owner shall notify any successor to title of all or part of the Property about the existence of this Agreement. Owner shall provide such notice prior to such successor obtaining an interest in all or part of the Property. Owner shall provide a copy of such notice to the City at the same time such notice is provided to the successor.
9. Time is of the essence in the performance of this Agreement.
10. Any notice or demand for payment to a party required or called for in this Agreement shall be served in person, or by deposit in the U.S. Mail, first class postage prepaid, to addresses listed on Page 1 of this agreement either for the Owner or City. Notice(s) shall be deemed effective upon receipt, or seventy-two (72) hours after deposit in the U.S. Mail, whichever is earlier. A party may change a notice address only by providing written notice thereof to the other party.

**IN WITNESS THEREOF**, the parties hereto have affixed their signatures as of the date first written above.

CITY OF STOCKTON, a  
Municipal corporation

ATTEST: APPROVED AS TO FORM:

By \_\_\_\_\_  
J. GORDON PALMER JR., CITY MANAGER

OFFICE OF THE CITY ATTORNEY

By \_\_\_\_\_  
Assistant City Attorney

(Name of facility in bold)

By \_\_\_\_\_  
PROPERTY OWNER

Name \_\_\_\_\_

Title \_\_\_\_\_

**CITY ACKNOWLEDGMENT**

STATE OF CALIFORNIA  
COUNTY OF SAN JOAQUIN)

On \_\_\_\_\_ before me, \_\_\_\_\_  
(Insert Name and Title of Officer)

personally appeared \_\_\_\_\_, who proved to me on the basis of satisfactory evidence to be the person(s) whose name(s) is/are subscribed to the within instrument and acknowledged to me that he/she/they executed the same in his/her/their authorized capacity(ies), and that by his/her/their signature(s) on the instrument the person(s), or the entity upon behalf of which the person(s) acted, executed the instrument.

I certify under PENALTY OF PERJURY under the laws of the State of California that the foregoing paragraph is true and correct.

WITNESS my hand and official seal.

\_\_\_\_\_  
Signature of Notary

(Seal)

**OWNER ACKNOWLEDGMENT**

STATE OF CALIFORNIA  
COUNTY OF \_\_\_\_\_ )

On \_\_\_\_\_ before me, \_\_\_\_\_  
(Insert Name and Title of Officer)

personally appeared \_\_\_\_\_, who proved to me on the basis of satisfactory evidence to be the person(s) whose name(s) is/are subscribed to the within instrument and acknowledged to me that he/she/they executed the same in his/her/their authorized capacity(ies), and that by his/her/their signature(s) on the instrument the person(s), or the entity upon behalf of which the person(s) acted, executed the instrument.

I certify under PENALTY OF PERJURY under the laws of the State of California that the foregoing paragraph is true and correct.

WITNESS my hand and official seal.

\_\_\_\_\_  
Signature of Notary (Seal)

**OWNER ACKNOWLEDGMENT**

STATE OF CALIFORNIA  
COUNTY OF \_\_\_\_\_ )

On \_\_\_\_\_ before me, \_\_\_\_\_  
(Insert Name and Title of Officer)

personally appeared \_\_\_\_\_, who proved to me on the basis of satisfactory evidence to be the person(s) whose name(s) is/are subscribed to the within instrument and acknowledged to me that he/she/they executed the same in his/her/their authorized capacity(ies), and that by his/her/their signature(s) on the instrument the person(s), or the entity upon behalf of which the person(s) acted, executed the instrument.

I certify under PENALTY OF PERJURY under the laws of the State of California that the foregoing paragraph is true and correct.

WITNESS my hand and official seal.

\_\_\_\_\_  
Signature of Notary (Seal)



**EXHIBIT A**

**(Operation & Maintenance Plan)**

**EXHIBIT B**

**(Deed Copy)**

**Owner's Certification Statement**

---

**OWNER'S CERTIFICATION**

**STORMWATER QUALITY CONTROL PLAN**

for

**(PROJECT NAME)**

This Project Stormwater Quality Control Plan (Plan) was prepared for       (Project Owner / Developer)       by       (Name of Preparing Firm/Individual)      . This Plan is intended to comply with all requirements specified in the City of Stockton Stormwater Quality Control Criteria Plan (SWQCCP) for new development and redevelopment projects.

The undersigned understands that stormwater pollution control measures are enforceable requirements under the SWQCCP. The undersigned, while owning the property on which such control measures are to be implemented, is responsible for the implementation of the provisions of this Plan and for the maintenance of all structural stormwater pollution control measures and agrees to ensure that the conditions on the project site conform to the requirements specified in the SWQCCP.

Once the undersigned transfers its interest in the project property, its successors-in-interest shall bear the aforementioned responsibility to maintain structural stormwater pollution control measures and to implement and amend this Plan.

Name of Owner

Address of Owner

Phone number of Owner

Signature \_\_\_\_\_

Print Name \_\_\_\_\_

Title \_\_\_\_\_

Date \_\_\_\_\_

**ENGINEER'S REPORT  
CANNERY PARK ZONE 2  
STOCKTON CONSOLIDATED STORM DRAINAGE MAINTENANCE  
ASSESSMENT DISTRICT NO. 2005-1  
CITY OF STOCKTON  
(PURSUANT TO THE MUNICIPAL IMPROVEMENT ACT OF 1913  
AND STOCKTON IMPROVEMENT PROCEDURE CODE, PART V)**

**FISCAL YEAR 2005-06**

**PREPARED BY:**

**Thompson-Hysell Engineers,  
a division of The Keith Companies, Inc.  
1016 12th Street  
Modesto, CA 95354**

**NOVEMBER 1, 2005**

**ENGINEER'S REPORT  
FOR THE 2005-06 FISCAL YEAR**

**CANNERY PARK ZONE 2  
STOCKTON CONSOLIDATED STORM DRAINAGE MAINTENANCE  
ASSESSMENT DISTRICT NO. 2005-1  
CITY OF STOCKTON**

(Pursuant to the Municipal Improvement Act of 1913 and  
Stockton Improvement Procedure Code, Part V)

The undersigned respectfully submits the enclosed Engineer's Report as directed by the City Council.

DATED: \_\_\_\_\_, 2005.

Thompson-Hysell Engineers  
Engineer of Work

BY:

Michael T. Persak  
RCE 44908

**I HEREBY CERTIFY** that the enclosed Engineer's Report, together with Boundary Map, Assessment, and Assessment Diagram thereto attached, was filed with me on the \_\_\_\_\_ day of \_\_\_\_\_, 2005.

\_\_\_\_\_, City Clerk, City of Stockton  
San Joaquin County, California

BY:

**I HEREBY CERTIFY** that the enclosed Engineer's Report, together with Assessment and Assessment Diagram thereto attached, was approved and confirmed by the City Council of the City of Stockton, California on the \_\_\_\_\_ day of \_\_\_\_\_, 2005.

\_\_\_\_\_, City Clerk, City of Stockton  
San Joaquin County, California

BY:

**I HEREBY CERTIFY** that the enclosed Engineer's Report, together with Assessment and Assessment Diagram thereto attached, was filed with the Auditor of the County of San Joaquin on the \_\_\_\_\_ day of \_\_\_\_\_, 2005.

\_\_\_\_\_, City Clerk, City of Stockton  
San Joaquin County, California

BY:

November 1, 2005

The Honorable Mayor and  
City Council of The City of  
Stockton, CA

To Whom It May Concern:

This report is prepared pursuant to and in compliance with the requirements of the “Municipal Improvement Act of 1913,” as amended, commencing with the Streets and Highways code sections 10000, et seq. and the Stockton Improvement Procedure Code, Part V, commencing with code sections 9-101, et seq, for the creation of a new Zone (Cannery Park Zone 2) in the Stockton Consolidated Storm Drainage Maintenance Assessment District No. 2005-1.

#### BACKGROUND

The Cannery Park project consists of a 960-lot residential subdivision, one multi-family residential lot, six commercial lots, one light industrial lot, one school site, two park sites, and a fire department site. The development is located in the north portion of the City of Stockton, on the south side of Eight Mile Road and the west side of the Highway 99 frontage road. The development is being pursued by Vascorp Investments Corporation. The Cannery Park project includes amenity improvements of various public areas. This report is relative to the proposed Cannery Park Zone 2 of the City of Stockton Consolidated Storm Drainage Maintenance Assessment District, which provides annual funds for the maintenance of various public storm drainage improvements. Exhibit A, the proposed annexation roll, details how each lot will be assessed.

#### PHASED DEVELOPMENT

Cannery Park is currently anticipated to be constructed in multiple units. The general nature of the storm drainage improvements for all units is described in the “Description of Facilities to be Maintained.” Annually, the additional storm drainage improvements and the additional subdivision developed areas, if any, shall be identified. The costs of the maintenance of the new improvements, if any, shall be added to and included in the next annual storm drainage maintenance budget. Cannery Park, when completed, will include approximately 960 single-family residential lots, one multi-family residential lot, six commercial lots, one light industrial lot, one school site, two park sites, and a fire department site.

## ASSESSMENT DISTRICT AREA

The area proposed to be formed into Zone 2 is described as all of the property within the following assessor's parcels identified by assessor's number (APN):

<u>Book</u>	<u>Page</u>	<u>Parcels</u>
092	040	03, 04, 05, 06, 07, 11, 12, 15, 16

A Boundary Map is attached to this Engineer's Report as Exhibit B. The Assessment Diagram for Cannery Park Zone 2 is attached to the Engineer's Report as Exhibit C. A County Assessors Map is also included. Exhibit D shows the areas to be maintained.

## PLANS AND SPECIFICATIONS

As various phases of this project are developed, plans and specifications for the storm drainage improvements to be maintained by the funds generated by Cannery Park Zone 2 are filed separately with the City of Stockton and are incorporated into this report by reference.

## DESCRIPTION OF FACILITIES TO BE MAINTAINED

Certain public storm drainage improvements are to be installed by the developers as part of the Conditions of Approval for the Cannery Park project. Cannery Park Zone 2 was created to provide funding for the continued maintenance of the storm drainage facilities, which are described below. During the installation period for each phase, the developer will maintain the new drainage improvements until the following June 30, at which time the new areas shall be incorporated into the storm drainage improvements already being maintained by the District.

Zone 2 is divided into two sub-zones, Zone 2-A and Zone 2-B. These represent the two separate drainage systems within the Cannery Park development.

The following improvements shall be included in Zone 2-A (Cannery Park Basin) upon their completion.

1. Description of Improvements (Zone 2-A, Cannery Park Basin)
  - A. An access road to be maintained.
  - B. An extended detention basin to be maintained and inspected semi-annually at the beginning and end of the wet season for: slope stability, sediment accumulation, trash and debris, presence of burrows, mowless grass or approved equivalent.
  - C. Inspection and treatment of Vector control.
  - D. Inspect and maintain wrought iron fence and gate that surrounds extended detention basin.

The following improvements shall be included in Zone 2-B (SJAFCA Basin #2) upon their completion.

2. Description of Improvements (Zone 2-B, SJAFCB Basin #2)

- A. Rip base surface of basin once annually.
- B. Manually turn low-flow summer pump on for ripping of surface and turn low-flow summer pump off after ripping of surface is complete.
- C. Inspection and treatment of Vector control.
- D. Pick up debris and trash in basin on semi-monthly basis.

ALLOCATION OF COSTS

Assessments for the Cannery Park Storm Drainage Maintenance Assessment District are apportioned in a manner intended to fairly distribute the amounts among all assessable developed parcels in proportion to the estimated benefits to be received by each such parcel. The assessment shall be levied on the basis of the adjusted drainage areas of each such lot and/or parcel. A parcel is considered as being developed by reason of having been included as a lot or parcel in the recorded Final Map(s) or being included within the active developed area in the case of an existing parcel. The criteria for apportioning the costs for the maintenance makes use of a dwelling unit equivalent Factor (*dueF*) to calculate the benefit for all uses in terms of equivalent dwelling units. The terms, definitions, and procedures followed to develop the annual assessments are as follows:

1. Calculation of Runoff Coefficient

All developed parcels shall be directly proportional to a single-family residential development, assuming 5 developed single-family lots per acre with a runoff coefficient of 0.35.

Example Calculation:

Determine *dueF* per acre for a developed parcel with a runoff coefficient of 0.65.

$$\frac{\text{Parcel (Developed)}}{0.65} = \frac{5 \text{ Single-Family (Developed)}}{0.35}$$

$$= \text{Parcel (Developed)} = 9.3 \text{ } dueF \text{ per Acre}$$

2. Dwelling Unit Equivalent Factor (*dueF*)

The *dueF* for each use is as follows:

A. Single-Family Residential

All parcels developed for single-family use shall be determined to have a runoff coefficient of 0.35 and a *dueF* of 1.0 for each parcel.

B. Multi-Family Residential

All parcels determined to be developed for multi-family residential shall be determined to have a runoff coefficient of 0.65 and a *dueF* of 9.3 per acre, which is representative of the increase in storm drainage runoff between a multi-family residential site and a single-family residential development.

- C. School Site  
All parcels developed for a school site shall be determined to have a runoff coefficient of 0.39 and a *dueF* of 5.56 per acre, which is representative of the increase in storm drainage runoff between a school site and a single-family residential development.
- D. Park Site  
All parcels developed for a park site shall be determined to have a runoff coefficient of 0.15 and a *dueF* of 2.14 per acre, which is representative of the decrease in storm drainage runoff between a park as compared to a single-family residential development.
- E. Industrial/Commercial/Fire Department  
All parcels developed for an industrial/commercial/fire department site shall be determined to have a runoff coefficient of 0.90 and a *dueF* of 12.9 per acre, which is representative of the increase in storm drainage runoff between an industrial/ commercial/fire department site as compared to a single-family residential development.
- F. Other Uses  
All parcels determined to have uses other than identified above shall have a *dueF* established at the time of the first annual budget affecting such areas as determined by the Engineer or other officer appointed by the City of Stockton to prepare the annual cost spread. The determined *dueF* shall follow the character of the factors assigned above as nearly as practicable, but the determination shall be the sole responsibility of the appointed party and the City of Stockton.

G. Zero Dwelling Unit Equivalent Factor (*dueF*)

Certain parcels, by reason of use, size, shape, or state of development, may be assigned a zero *dueF* which will consequently result in a zero assessment for that fiscal year. All parcels having such a zero *dueF* for the previous fiscal year shall annually be reconsidered to determine if the reason for assigning the zero *dueF* is still valid for the next fiscal year. Parcels which may be expected to have a zero *dueF* assigned are typically parcels which are all, or nearly all, publicly landscaped, and remainder parcels too small or narrow for reasonable residential or commercial use, unless actually in use.

3. Compilation

Annually, about May 15, following the determination of the *dueF* for all developed parcels and the determination of the list of developed parcels by APN for the next fiscal year, all single-family or duplex/triplex residential parcels shall have a *due* assigned to each parcel equal to the *dueF* for that parcel. For all parcels other than single-family or duplex/triplex residential parcels, the product of the *dueF* times the area or adjusted usable area of the parcel, as appropriate, shall be calculated and shall be the *due* assigned. For developed parcels, the sum of the *due* assigned to each single-family *due* for each other parcel shall equal the total *due* for the next fiscal year. The total amount of revenue required for the next fiscal year shall then be divided by the total *due* to calculate the assessment per *due* for the next fiscal year. Parcels defined as not developed for the purposes of determining the storm drainage maintenance assessments will all have a zero *dueF* and consequently a zero *due* and a zero assessment.

4. Allocation of Assessments

The assessment for maintenance for the next fiscal year shall then be set for each parcel as the product of the calculated dwelling unit equivalent (*due*) for each parcel, multiplied by the assessment per *due* for the next fiscal year.

METHOD OF ASSESSMENT SPREAD

In compliance with the provisions of Proposition 218, adding Article XIII D to the California Constitution, the benefits conferred on each parcel within Zone 2 of the Stockton Consolidated Storm Drainage Maintenance Assessment District No. 2005-1 are particular and distinct benefits (hereinafter “special benefits”) over and above general benefits conferred on such property or to the public at large, in that the individual number-designated zones in the District each represents a common unit to provide storm drainage quality control for the development of the property within the individual number-designated zones in the District generally for residential and related urban uses. Benefits are determined to be 100% special benefits and 0% general benefits. Also, in keeping with the requirements of Proposition 218, no annual individual assessments shall be increased above the amounts assessed under the established criteria for each zone for the preceding fiscal year without an election approval, except as provided by the annual escalation factor.

The assessments are to be levied on the basis of the adjusted drainage areas of each of such lots and/or parcels.

Pursuant to Article XIII D, Section 4, of the California Constitution, publicly owned properties which receive special benefit from the improvements must be assessed a proportionate share of the costs thereof.

The base objective of the assessment spread is to distribute costs in accordance with the benefits received. Costs will be spread equally to each residential lot, school site, park site, and industrial/ commercial/fire department site *due* as follows:

#### Zone 2-A

- A. Lots A, B, C, D, F, and Y.

#### Zone 2-B

- A. Village A, lots 1-51; Village B, lots 1-36; Village C, lots 1-47; Village D1, lots 1-86; Village D2, lots 1-87; Village E1, lots 1-129; Village E2, lots 1-102; Village F, lots 1-146; Village G1, lots 1-154; Village G2, lots 1-122; Lot E, school site, park sites, and fire department site.

As improvements are constructed in subsequent units of said subdivision, the cost of maintaining such additional improvements will be added to the cost of maintaining entire district improvements during each fiscal year following the completion of such additional improvements, and the total cost of such maintenance shall be assessed equally against all lots within the respective district.

#### ANNUAL ESCALATION

The maximum assessment amount for each fiscal year shall be increased in an amount equal to the greater of: 1) three percent (3.0%), or 2) the percentage increase of the Local Consumer Price Index (CPI). Consumer Price Index applied is for the San Francisco-Oakland-San Jose County Area for All Urban Consumers, as developed by the U.S. Bureau of Labor Statistics for a similar period of time.

#### ADMINISTRATION

It is intended that the City of Stockton, either directly or by subcontract, shall have the responsibility to establish an ongoing Storm Drainage Maintenance Management entity to be known as the Storm Drainage Maintenance District Manager which shall be responsible to establish the annual budget, keep an accounting of the maintenance and operational administrative costs, administer and perform the storm drain maintenance either directly or by subcontract, pay all fees, utility costs, taxes, and any and all other operating costs.

#### ESTIMATE OF COSTS

The estimated costs are for public storm drainage maintenance only. All initial improvements will be installed by the developer, at no cost to the Storm Drainage Maintenance Assessment District. The cost of maintaining the improvements will be paid by the developer to the District through the end of the fiscal year (June 30) and until such time as sufficient funds (not to exceed the total maximum assessment) are available from the District's annual assessments.

Items considered in the maintenance cost include, but are not limited to: regularly scheduled maintenance, and facility repair and replacement at the end of its useful life.

#### Storm Drainage Maintenance Assessment

The Cannery Park development is required to ensure that all property owners within the subdivision pay their proportionate share of the cost to maintain the storm drainage quality control facilities within the service area for the subdivision or serving the subdivision.

The annual costs estimated to be collected with the 2005-06 taxes for the initially developed area are as follows. Refer to the cost breakdowns which follow the estimated costs for detailed information on the items marked with an asterisk (\*).

**ZONE 2-A**

<b><u>OPERATION COSTS</u></b>	<b><u>MAXIMUM ANNUAL ASSESSMENT</u></b>	<b><u>FY 2005-06 ACTUAL ASSESSMENT</u></b>
Cannery Park Extended Detention Basin (Zone 2-A)		
Maintenance/Repair*	\$8,640.00	\$0.00
Watering Mowless Sod*	\$600.00	\$0.00
Replacement Reserve*	<u>\$2,000.00</u>	<u>\$0.00</u>
<i>Subtotal Extended Detention Basin Costs</i>	<i>\$11,240.00</i>	<i>\$0.00</i>
Wrought Iron Fence and Gate Maintenance (Zone 2-A)		
Maintenance/Graffiti Control*	\$2,400.00	\$0.00
Replacement Reserve*	<u>\$500.00</u>	\$0.00
<i>Subtotal Wrought Iron Fence and Gate Costs</i>	<i>\$2,900.00</i>	<i>\$0.00</i>
Inspection/Management*	<u>\$1,680.00</u>	<u>\$0.00</u>
Total Operation Costs	\$15,820.00	\$0.00

<u>OPERATION COSTS</u>	<u>MAXIMUM ANNUAL ASSESSMENT</u>	<u>FY 2005-06 ACTUAL ASSESSMENT</u>
<b><u>DISTRICT ADMINISTRATION COSTS (Split Equally Between Zones 2-A and 2-B)</u></b>		
Attorney Fees	(\$1,500.00)	\$750.00
Annual Engineers' Report	(\$2,000.00)	\$1,000.00
Publication	(\$200.00)	\$100.00
City Administration Fee	(\$5,000.00)	\$2,500.00
County Administration Fee	(\$1,000.00)	\$500.00
Total Administration Costs	\$4,850.00	\$4,850.00
<b>Total Operation and Administration Costs</b>	<b>\$20,670.00</b>	<b>\$4,850.00</b>
<b>Estimated Contingency (10±%)</b>	<b>\$2,078.62</b>	<b>\$485.00</b>
<b>Total Estimated Revenue Required for 2005-06 Fiscal Year</b>	<b>\$22,748.62</b>	<b>\$5,335.00</b>
<b>Total Appropriation Required from Existing Fund Balance</b>	<b>\$0.00</b>	<b>\$0.00</b>
<b>Total Estimated Assessment for 2005-06 Fiscal Year</b>	<b>\$22,748.62</b>	<b>\$5,335.00</b>
<b>Developer's Contribution</b>	<b>\$0.00</b>	<b>\$5,335.00</b>
<b>Total dueF</b>	<b>1,999</b>	<b>0</b>
<b>Estimated Assessment per dueF</b>	<b>\$11.38</b>	<b>\$0.00</b>

ZONE 2-A COST BREAKDOWN

*Cannery Park Extended Detention Basin*

**Maintenance/Repair: 12 site visits for trash pickup, mowless sod check and repair, slope check and repair, berm check and repair, low-flow channel check and repair, sprinkler check and repair at \$470.00 per site visit (including materials for repair) = \$5,640.00; Vector Control inspection and spraying (including materials) = \$3,000.00**

**Watering Mowless Sod: \$600.00**

**Replacement Reserve: \$2,000.00 (x 50 years = \$100,000.00 + 3% interest rate)**

*Wrought Iron Fence and Gate Maintenance*

**Maintenance/Graffiti Control:** 12 site visits to remove graffiti at \$200.00 per site visit = \$2,400.00

**Replacement Reserve:** \$500.00 (x 50 years = \$25,000.00 + 3% interest rate)

**Inspection/Management:** 2 hours per month x 12 months per year x \$70.00 per hour = \$1,680.00

**ZONE 2-B**

<b><u>OPERATION COSTS</u></b>	<b><u>MAXIMUM ANNUAL ASSESSMENT</u></b>	<b><u>FY 2005-06 ACTUAL ASSESSMENT</u></b>
SJAFCA Basin #2 (Zone 2-B)		
Vector Control*	\$3,000.00	\$3,000.00
Rip Basin Bottom*	\$7,000.00	\$7,000.00
Low Flow Pump Operations*	\$500.00	\$500.00
Debris/Trash Maintenance*	<u>\$1,680.00</u>	<u>\$1,680.00</u>
<i>Subtotal SJAFCA Basin #2 Costs</i>	<i>\$12,180.00</i>	<i>\$12,180.00</i>
Inspection/Management*	<u>\$1,680.00</u>	<u>\$1,680.00</u>
<b>Total Operation Costs</b>	<b>\$13,860.00</b>	<b>\$13,860.00</b>

**DISTRICT ADMINISTRATION COSTS (Split Equally Between Zones 2-A and 2-B)**

Attorney Fees	(\$1,500.00)	\$750.00	\$750.00
Annual Engineers' Report	(\$2,000.00)	\$1,000.00	\$1,000.00
Publication	(\$200.00)	\$100.00	\$100.00
City Administration Fee	(\$5,000.00)	\$2,500.00	\$2,500.00
County Administration Fee	(\$1,000.00)	<u>\$500.00</u>	<u>\$500.00</u>
<i>Total Administration Costs</i>		<i>\$4,850.00</i>	<i>\$4,850.00</i>
<b>Total Operation and Administration Costs</b>		<b>\$18,710.00</b>	<b>\$18,710.00</b>
<b>Estimated Contingency (10±%)</b>		<b>\$1,867.66</b>	<b>\$1,867.66</b>
<b>Total Estimated Revenue Required for 2005-06 Fiscal Year</b>		<b>\$20,577.66</b>	<b>\$20,577.66</b>
<b>Total Appropriation Required from Existing Fund Balance</b>		<b>\$0.00</b>	<b>\$0.00</b>
<b>Total Estimated Assessment for 2005-06 Fiscal Year</b>		<b>\$20,577.66</b>	<b>\$20,577.66</b>
<b>Developer's Contribution</b>		<b>\$0.00</b>	<b>\$19,866.86</b>
<b>Total dueF</b>		<b>1,158</b>	<b>40</b>

Estimated Assessment per dueF

\$17.77

\$17.77

**ZONE 2-B COST BREAKDOWN**

**SJAFCA Basin #2**

**Vector Control:** Vector Control inspection and spraying (including materials) = \$3,000.00

**Rip Basin Bottom:** Excavate temporary swale from north inlet along west base to inlet of pump station; Rip surface approximately 4-5 feet = \$7,000.00

**Low Flow Pump Operations:** Turn summer pump on for approximately one week to drain basin for maximum surface dry out; Turn summer pump off = \$500.00

**Debris/Trash Maintenance:** (Semi-monthly visits) 2 hours per visit x 2 visits per month = 4 hours per month x 12 months x \$35.00 per hour = \$1,680.00

**Inspection/Management:** 2 hours per month x 12 months per year x \$70.00 per hour = \$1,680.00

## ASSESSMENT ROLLS

The assessment roll for proposed Zone 2-A for the fiscal year 2005-06 is as follows:

Assessment No.	APN No.	Cannery Park Future Lot Nos.	Owner	No. of <i>dueF's</i>	Maximum Annual Assessment	FY 2005-06 Actual Assessment
1	092-040-03	Lot A (20.49 acres) (264 <i>dueF's</i> ); Basin	Vascorp Investments Corporation	264	\$3,004.32	\$0.00
2	092-040-04	Lot A (21.1 acres) (272 <i>dueF's</i> ), Lot B (11.3 acres) (146 <i>dueF's</i> ); Basin	Vascorp Investments Corporation	418	\$4,756.84	\$0.00
3	092-040-05	Lot B (2.0 acres) (26 <i>dueF's</i> )	Vascorp Investments Corporation	26	\$295.88	\$0.00
4	092-040-06	Lot B (10.0 acres) (129 <i>dueF's</i> ); Lot C (7.9 acres) (102 <i>dueF's</i> ); Lot D (37.4 acres) (482 <i>dueF's</i> ); Lot F (12.2 acres) (157 <i>dueF's</i> ); Lot Y (5.5 acres) (71 <i>dueF's</i> )	Vascorp Investments Corporation	941	\$10,708.58	\$0.00
5	092-040-16	Lot A (27.1 acres) (350 <i>dueF's</i> )	Vascorp Investments Corporation	350	\$3,983.00	\$0.00
Developer's Contribution				0	\$0.00	\$5,335.00
<b>Total</b>				1,999	\$22,748.62	\$5,335.00

The assessment roll for proposed Zone 2-B for the fiscal year 2005-06 is as follows:

Assessment No.	APN No.	Cannery Park Future Lot Nos.	Owner	No. of <i>dueF's</i>	Maximum Annual Assessment	FY 2005-06 Actual Assessment*
1	092-040-03	Village E1, Lots 20-34, 97-129; Village E2, Lots 1-6, 40-69 (84 <i>dueF's</i> ); Park (1.12 acres) (2 <i>dueF's</i> )	Vascorp Investments Corporation	86	\$1,528.22	\$0.00
2	092-040-04	Village E1, Lots 1-19, 35-96; Village A, Lots 1-51; Village B, Lots 1-36 (168 <i>dueF's</i> )	Vascorp Investments Corporation	168	\$2,985.36	\$0.00
3	092-040-06	Village C, Lots 1-47 (47 <i>dueF's</i> ); Lot E (11.7 acres) (109 <i>dueF's</i> )	Vascorp Investments Corporation	156	\$2,772.12	\$0.00
4	092-040-11	Village D1, Lots 1-86; Village D2, Lots 1-87; Village F, Lots 4-41, 49-73; Village G1, Lots 9-50 (278 <i>dueF's</i> ); Fire Department (2.17 acres) (28 <i>dueF's</i> )	Vascorp Investments Corporation	306 <b>*Unit D1 – Lots 1-40</b>	\$5,437.62	\$710.80
5	092-040-12	Village F, Lots 1-3, 42-48, 74-146; Village G1, Lots 1-8, 51-154; Village G2, Lots 1-49, 59-81, 84-122 (306 <i>dueF's</i> ); Park (6.45 acres) (14 <i>dueF's</i> ); School (8.07 acres) (45 <i>dueF's</i> )	Vascorp Investments Corporation	365	\$6,486.05	\$0.00
6	092-040-15	Village G2, Lots 50-58, 82, 83 (11 <i>dueF's</i> )	Vascorp Investments Corporation	11	\$195.47	\$0.00
7	092-040-16	Village E2, Lots 7-39, 70-102 (66 <i>dueF's</i> )	Vascorp Investments Corporation	66	\$1,172.82	\$0.00
Developer's Contribution				0	\$0.00	\$19,866.86
<b>Total</b>				1,158	\$20,577.66	\$20,577.66

The parcels in the Cannery Park subdivision are expected to subdivide upon and subsequent to the proposed formation of Zone 2. The proposed subdivision will yield approximately 960 residential lots (960 *dueF's*), 1 multi-family residential lot (109 *dueF's*), 7 commercial/light industrial parcels (1,999 *dueF's*), 2 park sites (16 *dueF's*), a school site (45 *dueF's*), and a fire department site (28 *dueF's*), and will have a proposed assessment roll, based on the above criteria and budget, as set forth in Exhibit A for Zones 2-A and Zone 2-B.

The foregoing Engineer's Report and the estimate of costs, as well as the Boundary Map, Assessment Diagram, and Assessment Roll which are attached hereto, are presented for your approval by resolution dated this \_\_\_\_\_ day of \_\_\_\_\_, 2005.

THOMPSON-HYSELL ENGINEERS  
Engineer of Work  
BY:

Michael T. Persak  
RCE 44908

This appendix includes the following maintenance agreements and forms:

E-1: Project Stormwater Quality Control Plan Guidance

E-2: Maintenance Plan Guidance

## ***Project Stormwater Quality Control Plan Guidance***

---

**This appendix identifies the basic information that shall be included and format that shall be followed in a Project Stormwater Quality Control Plan (SWQCP) pursuant to the City of Stockton and County of San Joaquin SWQCCP.**

A. Cover page including:

- Project Name
- Owner/Developer's name and contact information
- Plan Preparer's name and contact information
- Date submitted (first submittal)
- Date revised (subsequent submittals, as required)

B. Owner's Certification Statement (see Appendix D-2 for sample statement)

C. Project Description

1. Project Category (see Section 2)
2. Narrative description of project – size, location, pollutants of concern, land uses, etc.
3. Site maps
  - a. Provide a vicinity map showing the location of the project relative to principal landmarks.
  - b. Provide a site map showing boundaries of the site, acreage and drainage patterns/contour lines. Show each discharge location from the site and any drainage flowing onto the site.
  - c. Identify locations of existing and proposed storm drain facilities, private sanitary sewer systems and grade-breaks for purposes of pollution prevention.
  - d. With legend, show locations of expected sources of pollution generation (outdoor work and storage areas, heavy traffic areas, delivery areas, trash enclosures, fueling areas, industrial clarifiers, wash-racks, etc). Identify any areas having contaminated soil or where toxins are stored or have been stored/disposed of in the past.
  - e. With legend, indicate types and locations of structural stormwater control measures that will be built to permanently control stormwater pollution.

D. Stormwater Pollution Control Measures

1. Provide summary matrix indicating each type of control measure provided (see Section 2).
2. Site Design Controls
  - a. Describe the controls provided under each Site Design Control (G-1 through G-4). Indicate how site design will conform to design criteria listed in SWQCCP.

- b. If a Site Design Control is not applicable to the project, provide a statement of justification describing why the control measure is not applicable to the project.
    - c. If implementation of a Site Design Control is not feasible due to project site conditions, provide a statement of justification describing why implementation is not feasible.
  - 3. Source Controls
    - a. Describe the source controls to be provided (Note: Source Control S-1 is required for all projects). Indicate how design of source controls will conform to design criteria listed in SWQCCP.
  - 4. Volume Reduction Measures
    - a. Describe the volume reduction measures to be provided.
    - b. Use the summary sheet in Appendix B to track compliance with the Volume Reduction Requirement.
    - c. If implementation of Volume Reduction Measures is not feasible and/or the Volume Reduction Requirement cannot be met, use the Waiver Application in Appendix to justify why implementation is not feasible. All Volume Reduction Measures must be taken into consideration.
  - 5. Treatment Control Measures
    - a. Describe the treatment control measures to be provided.
    - b. If the Volume Reduction Requirement was not fully met through the use of Volume Reduction Measures, LID Treatment Controls must be used and the summary sheet in Appendix B should be used to continue tracking compliance with the Volume Reduction Requirement. If implementation of Volume Reduction Measures is not feasible and/or the Volume Reduction Requirement cannot be met, use the Waiver Application in Appendix to justify why implementation is not feasible. All Volume Reduction Measures must be taken into consideration.
    - c. Summarize design data for treatment control measures on appropriate design procedure forms (see Appendix I for forms). Provide detailed supporting calculations for design data values in a clear and organized manner.
- E. Maintenance Plan and Responsibility
- 1. Provide a summary of structural control measures to be provided and parties responsible for maintenance of each control. Indicate any anticipated transfer of responsibility due to future transfer of ownership or annexation.
  - 2. Provide complete contact information for each listed responsible party
  - 3. Provide a statement that a detailed Maintenance Plan will be prepared in accordance with SWQCCP requirements (see Appendix D for guidance).

**This appendix identifies the basic information that shall be included in a maintenance plan. Refer to Fact Sheets for individual control measures regarding device-specific maintenance requirements.**

**A. Site Map:**

1. Provide a site map showing boundaries of the site, acreage and drainage patterns/contour lines. Show each discharge location from the site and any drainage flowing onto the site. Distinguish between soft and hard surfaces on the map.
2. Identify locations of existing and proposed storm drain facilities, private sanitary sewer systems and grade-breaks for purposes of pollution prevention.
3. With legend, show locations of expected sources of pollution generation (outdoor work and storage areas, heavy traffic areas, delivery areas, trash enclosures, fueling areas, industrial clarifiers, wash-racks, etc). Identify any areas having contaminated soil or where toxins are stored or have been stored/disposed of in the past.
4. With legend, indicate types and locations of stormwater control measures that will be built to permanently control stormwater pollution. Distinguish between pollution prevention, treatment, sewer diversion, and containment devices.

**B. Baseline Descriptions:**

1. List the property owners and persons responsible for operation and maintenance of the stormwater control measures on site. Include phone numbers and addresses.
2. Identify the intended method of providing financing for operation, inspection, routine maintenance and upkeep of stormwater control measures.
3. List all permanent stormwater control measures. Provide a brief description of stormwater control measures selected and if appropriate, facts sheets or additional information.
4. As appropriate for each stormwater control measure provide:
  - a. A written description and check list of all maintenance and waste disposal activities that will be performed. Distinguish between the maintenance appropriate for a 2-year establishment period and expected long-term maintenance. For example, maintenance requirements for vegetation in a constructed wetland may be more intensive during the first few years until the vegetation is established. The post-establishment maintenance plan shall address maintenance needs (e.g. pruning, irrigation, weeding) for a larger, more stable system. Include maintenance performance procedures for facility components that require relatively unique maintenance knowledge, such as specific plant removal/replacement, landscape features, or constructed wetland maintenance. These procedures shall provide enough detail for a person unfamiliar with maintenance to perform the activity, or identify the specific skills or knowledge necessary to perform and document the maintenance.

- b. A description of site inspection procedures and documentation system, including record-keeping and retention requirements.
  - c. An inspection and maintenance schedule, preferably in the form of a table or matrix, for each activity for all facility components. The schedule shall demonstrate how it will satisfy the specified level of performance, and how the maintenance/inspection activities relate to storm events and seasonal issues.
  - d. Identification of the equipment and materials required to perform the maintenance.
5. As appropriate, list all housekeeping procedures for prohibiting illicit discharges or potential illicit discharges to the storm drain. Identify housekeeping BMPs that reduce maintenance of treatment control measures.

**C. Spill Plan:**

1. Provide emergency notification procedures (phone and agency/persons to contact).
2. As appropriate for site, provide emergency containment and cleaning procedures.
3. Note downstream receiving water bodies or wetlands which may be affected by spills or chronic untreated discharges.
4. As appropriate, create an emergency sampling procedure for spills. (Emergency sampling can protect the property owner from erroneous liability for down-stream receiving area clean-ups).

**D. Facility Changes:**

1. Operational or facility changes which significantly affect the character or quantity of pollutants discharging into the stormwater control measures will require modifications to the Maintenance Plan and/or additional stormwater control measures.

**E. Training:**

1. Identify appropriate persons to be trained and assure proper training.
2. Training to include:
  - a. Good housekeeping procedures defined in the plan.
  - b. Proper maintenance of all pollution mitigation devices.
  - c. Identification and cleanup procedures for spills and overflows.
  - d. Large-scale spill or hazardous material response.
  - e. Safety concerns when maintaining devices and cleaning spills.

**F. Basic Inspection and Maintenance Activities:**

1. Create and maintain on site, a log for inspector names, dates and stormwater control measure devices to be inspected and maintained. Provide a checklist for each inspection and maintenance category.
2. Perform annual testing of any mechanical or electrical devices prior to wet weather.

3. Report any significant changes in stormwater control measures to the site management. As appropriate, assure mechanical devices are working properly and/or landscaped BMP plantings are irrigated and nurtured to promote thick growth.
4. Note any significant maintenance requirements due to spills or unexpected discharges.
5. As appropriate, perform maintenance and replacement as scheduled and as needed in a timely manner to assure stormwater control measures are performing as designed and approved.
6. Assure *unauthorized* low-flow discharges from the property do not by-pass stormwater control measures.
7. Perform an annual assessment of each pollution generation operation and its associated stormwater control measures to determine if any part of the pollution reduction train can be improved.

**G. Revisions to Pollution Mitigation Measures:**

1. If future correction or modification of pass stormwater control measures or procedures is required, the owner shall obtain approval from the governing stormwater agency prior to commencing any work. Corrective measures or modifications shall not cause discharges to by-pass or otherwise impede existing stormwater control measures.

**H. Monitoring & Reporting Program**

1. The governing stormwater agency may require a Monitoring & Reporting Program to assure the stormwater control measures approved for the site are performing according to design.
2. If required by local agency, the Maintenance Plan shall include performance testing and reporting protocols.

This appendix includes information on the Hydrologic Soil Groups in San Joaquin County to use in designing various stormwater control measures:

### ***Relevance of Hydrologic Soil Groups Information***

The hydrologic soil groups of a development area are pertinent to design of controls that involve infiltration and for identifying sites appropriate for detention basins. The predominant soil group will control the effectiveness of infiltration facilities or the suitability of an area for impounding water. Hydrologic soil group information should be used for preliminary siting studies only. Actual design should be based on in-situ soil investigations and testing by a qualified engineer or geologist.

**Table F-1. Typical Infiltration Rates**

<b>Soil Type (Hydrologic Soil Group)</b>	<b>Infiltration Rate (in/hr)</b>
A	1.00 – 8.3
B	0.5 – 1.00
C	0.17 – 0.27
D	0.02 – 0.10

Infiltration rates shown represent the range covered by multiple sources, e.g. ASCE, BASMAA, etc.

### ***Hydrologic Soil Groups***

The hydrologic soil groups are classified by the USDA Natural Resources Conservation Service (NRCS), formerly the Soil Conservation Service. There are four hydrologic soil groups: A, B, C and D. Soils may be classified by two groups. Soil groups A and B have the highest infiltration rates, unless the soils under consideration have been compacted during construction. Soil groups A and B are typically the best candidate soils for construction of infiltration facilities. Sites with soil groups C and D are usually more appropriate for detention basins.

Soils in group A have a low runoff potential and high infiltration rate, as the soils typically are sands and gravel. Soil group B includes soils with moderate infiltration rates when completely wetted. Group B soils are sandy loam soils with moderately fine to moderately coarse textures. Soils in group C have slow infiltration rates when thoroughly wetted and these soils typically are silty-loam soils with an impeding layer or soils with moderately fine to fine texture. Group D soils have a high runoff potential and very slow infiltration rate when thoroughly wetted. Group D soils include clay soils with high swelling potential, soils in a permanent high water table and shallow soils over nearly impervious material.

The hydrologic soil information presented here should be used as a general overview. For more specific information, consult the *San Joaquin County Soil Survey* (USDA, NRCS) or contact the NRCS at (530) 662-3986.

**THIS PAGE INTENTIONALLY LEFT BLANK**

## *Plants Suitable for Vegetative Control Measures*

Vegetation serves primarily to maintain soil porosity and prevent erosion. The effectiveness and aesthetic appeal of control measures are enhanced by selection of appropriate vegetative cover. Turf grass is preferred, and some other ground covers also may be appropriate. An important maintenance consideration in the selection of appropriate vegetation is whether irrigation is planned for the site. Consult with City stormwater staff regarding selection of appropriate vegetation.

Table G-1 provides a sample list of appropriate vegetative covers. Additional suggested vegetative species are listed in Table F-2. The tables are intended as guides in selecting vegetative covers. For specific species suitability and care information, refer to the sources listed for these tables. Contact the Natural Resources Conservation Service for additional information.

**Table G-1. Sample List of Appropriate Vegetative Covers**

<b>Plant Name Common (Latin)</b>	<b>Appropriate Species</b>	<b>Maintenance and Usage Notes*</b>
Bermuda Grass (Cynodon)	Santa Ana hybrid Common	Moderate maintenance. Dormant (brown) in winter. Heat tolerant. Erosion control, swales.
Fescue (Festuca)	Red fescue (F. rubra)	Low to moderate maintenance. Tolerates some shade and poor soil. Lawns, swales, erosion control.
	"Kentucky 31" Tall Fescue (F. elatior)	Low maintenance. Tolerate shade and compacted soils. Rapid germination. Lawns, swales, erosion control. Useful as overseed for Bermuda grass during dormant (winter) season.
Ryegrass (Lolium)	Perennial (L. perenne)	Moderate maintenance. Heat intolerant. Fast sprouting. Useful as overseed for Bermuda grass during dormant (winter) season. Swales.
	Annual (L. multiflorum)	Annual (may live several seasons in mild climate). Moderate maintenance. Heat intolerant. Fast growing. Useful as overseed for winter-dormant species. Swales.

\*Generally, these species will require supplemental irrigation.

Sources: ASCE, MWCG, Sunset

**Table G-2. Additional Suggested Vegetative Covers**

<b>Plant Name Common (Latin)</b>	<b>Appropriate Species</b>	<b>Usage Notes</b>
Kentucky Bluegrass	( <i>Poa pratensis</i> )	Irrigated Sites
Orchard grass ( <i>Dactylis</i> )	“Akaroa” or “Berber” ( <i>D. glomerata</i> )	Irrigated and Non-irrigated Sites
Wheatgrass ( <i>Agropyron</i> )	“Luna” or “Topar” pubescent ( <i>A. intermedium trichophorum</i> )	Irrigated and Non-irrigated Sites
Zorro Fescue ( <i>Vulpia</i> )	( <i>V. myuros</i> )	Irrigated and Non-irrigated Sites
Creeping wild Rye ( <i>Leymus</i> )	( <i>L. triticoides</i> )	Nonirrigated Sites
Brome ( <i>Bromus</i> )	Blando ( <i>B. mollis</i> )	Nonirrigated Sites
	California or “Cucamonga” ( <i>B. carinatus</i> )	Nonirrigated Sites

Sources: NRCS-FOTG. *Manual of Standards for Erosion and Sediment Control Measures*, Association of Bay Area Governments, 1995.

---

## ***Standard Calculations for Diversion Structure Design***

---

### ***Introduction***

Stormwater runoff in excess of the water quality flow or volume is to be diverted around or through the treatment control measure. The following paragraphs provide equations and design criteria necessary to design diversion structures to divert runoff in excess of the SQDV or SDQF around or through the treatment control measures.

### ***Diversion Structure Design***

Capture or isolation of the SQDV is typically achieved by employing one of the following techniques:

- Divert the SQDV into the treatment control measure from the on-site storm drain system using weirs or orifices at or upstream of the point of entrance to the treatment control measure.
- Bypassing flows in excess of the SQDV within the treatment control measure using weirs and pipes for channel or pipe storm drain systems or routing excessive flows through a vegetated swale.

By employing diversion techniques, the water quality flow or volume is treated and discharged to the storm drain system and runoff that exceeds the water quality flow or volume is diverted or bypassed, untreated, directly to the downstream storm drain system.

Equations and criteria to design a diversion structure are provided below. Alternative designs may be considered subject to approval.

All diversion structures are designed using the on-site storm design event. The drainage design storm is established by the governing agency and is not the same as the stormwater quality design flow or volume. The drainage design storm is used to design the conveyance system, i.e. pipes, swales, etc. of the site without regard for treatment. The design engineer must ensure sufficient head room in the on-site system above the diversion to accommodate overflows.

### ***Diverting Flows at the Inlet or Upstream of the Treatment Control Device***

Diverting flow at the inlet to the treatment control is the more common approach to divert excess runoff. Figure H-1 illustrates the more commonly used diversion structures. The height of the weir to divert the flow is determined as follows:

#### **Treatment Control Measures Designed Based on the SQDV**

1. Determine the SQDV (see Section 6)
2. Utilizing design techniques provided in the treatment control measure fact sheets, determine the maximum height of the water level in the treatment control measure when the entire SQDV is being held,
3. Set the height of the diversion weir to the maximum height of the water level.
4. Determine weir dimensions needed to divert peak flows of the drainage design storm using the following equation for a rectangular sharp-crested weir

$$Q_d = C \times L \times h^{1.5} \quad \text{eqn H-1}$$

- Where:
- $Q_d$  = Peak flow rate for drainage design storm, cfs
  - L = Effective length of weir, ft
  - C = Weir discharge coefficient
  - h = Depth of the flow above the crest of the weir, ft

The discharge coefficient “C” accounts for many factors, such as velocity of approach, in the weir equation. The height of the weir (H) and the height of the flow over the weir (h) are two characteristics of the sharp-crested weir that affect the value of C. Table H-1 can be used to approximate C for rectangular sharp-crested weirs without end contractions.

5. Provide sufficient head room in the treatment control to accommodate depth of flow over the weir.

**Table H-1. Weir Discharge Coefficient (C) for Rectangular Sharp-crested Weirs Without End Contractions<sup>1</sup>**

H/h	Head (h) over weir, ft						
	0.2	0.4	0.6	0.8	1.0	2.0	5.0
0.5	4.18	4.13	4.12	4.11	4.11	4.10	4.10
1.0	3.75	3.71	3.69	3.68	3.68	3.67	3.67
2.0	3.53	3.49	3.48	3.47	3.46	3.46	3.45
10.0	3.36	3.32	3.30	3.30	3.29	3.29	3.28
∞	3.32	3.28	3.26	3.26	3.25	3.25	3.24

1. From Lindsay and Franzini , (1979)

Treatment Control Measures Designed Based on the SQDF

1. Establish the size of the on-site drainage system (pipe diameter or dimensions) based on the drainage design storm
2. Determine the SQDF (see Section 6)
3. Determine the depth of flow in the on-site drainage system when carrying the SQDF using Manning’s equation (eqn H-2)

$$SQDF = \frac{1.49}{n} (A)(R)^{\frac{2}{3}} (s)^{\frac{1}{2}} \quad \text{eqn H-2}$$

- Where:
- SQDF = Water Quality Flow, cfs
  - n = Manning’s roughness coefficient
  - A = Cross sectional area of drainage pipe or channel, ft<sup>2</sup>
  - R = Hydraulic radius, ft
  - S = Slope of pipe or channel, ft/ft

4. Using nomographs or computer programs, determine the depth of flow at SQDF. Set the

weir height at this depth.

5. Using Equation H-1, establish weir dimensions. Provide sufficient head room in treatment control to accommodate flows over the weir.

### ***Bypassing Excess Flows within the Treatment Control Measure***

For certain site conditions, bypassing runoff in excess of the SQDV must be achieved in the treatment control measure. When this occurs, the control measure must be designed to ensure the bypass system can be accommodated in the unit, i.e. sufficient depth, width and length to accommodate pipes, length of weirs, etc. The following discusses design considerations for the different treatment control measures.

### **Bypassing Flows through Infiltration and Sedimentation/Filtration Treatment Control Measures**

Weirs, orifices or pipes in treatment control measures are used to bypass runoff in excessive of the SQDV and SQDF. Design of these measures is similar to the approach described above under diverting flows at the inlet to the treatment control measure. Bypass for filtration devices occurs in the sedimentation chamber.

#### *Weirs*

Weirs are commonly used to bypass excess storm events. Determining the height of the weir is based on the maximum water elevation in a treatment control device when holding the entire SQDV. To design the weir, use the procedures established under Diversion Structures for Treatment Control Measures Designed Using the SQDV.

#### *Orifices*

Orifices can be considered in place of weirs or pipes. To avoid drawing floatables into the bypass, a hooded orifice (see Figure H-2) should be designed using the equation H-3:

$$Q_d = C \times A \times (2gh)^{0.5} \quad \text{eqn H-3}$$

Where:  $Q_d$  = Peak flow rate for drainage design storm, cfs

$C$  = Orifice discharge coefficient, (use 0.6)

$A$  = Area of orifice, ft<sup>2</sup>

$h$  = Depth of the water above midpoint of orifice, ft

$g$  = 32.2 ft/sec<sup>2</sup>

Hoods should extend into one-third of the permanent pool depth or one-foot whichever is greater. Commercial catch basin traps can be used in lieu of a hood.

Determining the elevation of the orifice is based on determining the maximum water elevation in a treatment control device when holding the entire SQDV. Use the procedures established under Diversion Structures for Treatment Control Measures Designed Using the SQDV to establish the elevation of the mid-point of the orifice opening.

The size of the orifice is determined by using Equation H-3 for the orifice to bypass the peak flow of the on-site storm.

Ensure sufficient head room in the treatment unit to accommodate flows through orifice.

## *Pipes*

Pipes can also be employed to bypass excess runoff. Determining the invert elevation of the bypass inlet is based on determining the maximum water elevation in a treatment control device when holding the entire SQDV. To do this, use the procedures established under Diversion Structures for Treatment Control Measures Designed Using the SQDV to design a diversion weir.

For filtration control measures, a hooded inlet using a 90° elbow should be considered at the inlet to the bypass pipe to prevent drawing floatables into the bypass (see Figure H-2). Hoods should extend into one-third of the permanent pool depth or one-foot whichever is greater. Commercial catch basin traps can be used in lieu of a hood.

For infiltration control measures (see Figure H-3) bypass pipes are perforated and wrapped with filter fabric to avoid drawing sediment and small particles into the bypass pipe. Hoods are not necessary for these overflow pipes.

Bypass pipes are sized using the Manning's equation (Equation H-4) and sized to pass the peak flow of the drainage design storm, and assume the bypass pipes are flowing full.

With this assumption, the Manning's equation, Equation H-4, reduces to:

$$D = \left( \frac{2.159Q_d n}{s^{\frac{1}{2}}} \right)^{\frac{3}{8}} \quad \text{eqn H-4}$$

Where:     D = Diameter of pipe, ft  
              Q<sub>d</sub> = Peak flow rate for drainage design storm, cfs  
              n = Manning's coefficient for pipe material  
              s = Slope of pipe, ft/ft (0.5% minimum required)

Provide sufficient head room in the treatment control to accommodate flows.

## Routing Excess Runoff Through a Vegetated Swale

The depth of flow in a Vegetated Swale at SQDF is determined using a roughness coefficient of 0.2. If additional flows beyond the SQDF are to be directed to the vegetated swale, the roughness coefficient for these flows will be lower (approximately 0.03), because the flows exceeding the SQDF do not flow through the swale and are only influenced by surface friction/roughness. Swales with distinctly different roughness coefficients can be designed using an equivalent roughness coefficient that is determined based on the roughness associated with the wetted perimeters (P). For most on-site Vegetated Swale designs, there will be two different "n" values. An equivalent "n<sub>e</sub>" value can be determined using equation H-5:

$$n_e^{\frac{3}{2}} = \frac{P_1 n_1^{\frac{3}{2}} + P_2 n_2^{\frac{3}{2}}}{P} \quad \text{eqn H-5}$$

An iterative approach is used to develop an equivalent "n<sub>e</sub>", that can be calculated with most computer hydraulic program applications:

1. Estimate an equivalent roughness coefficient (estimated "n<sub>e</sub>");

2. Use the estimated roughness coefficient to determine the depth of flow using trial and error solution of Equation H-2 substituting the peak flow of the drainage design storm for the SQDF;
3. Use the calculated depth to determine the wetted perimeter for the drainage system;
4. Use the wetted perimeter associated with each “n” for the drainage system and using Equation H-5 to calculate the equivalent roughness coefficient (calculated “ $n_e$ ”), and compare to the estimated “ $n_e$ ”; and
5. Continue the process until the calculated “ $n_e$ ” equals the estimated “ $n_e$ ”. This value is the equivalent roughness coefficient and used to design the Vegetated Swale according to recommendations provided in Fact Sheet L-7.

Note - This approach results in conservative n values. High flows in the swale may cause some vegetation to bend resulting in a lower  $n_1$  and lower equivalent “ $n_e$ ”.

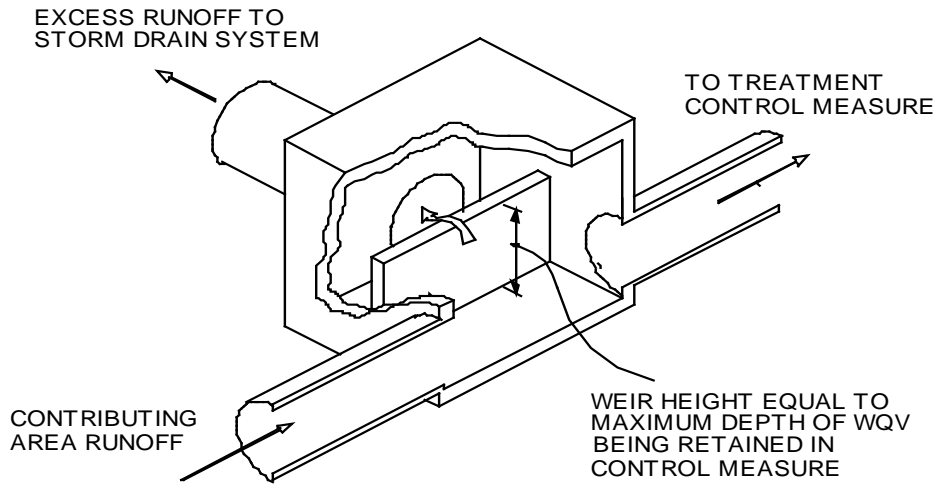

PIPE INTERCEPTOR ISOLATION/DIVERSION STRUCTURE

---

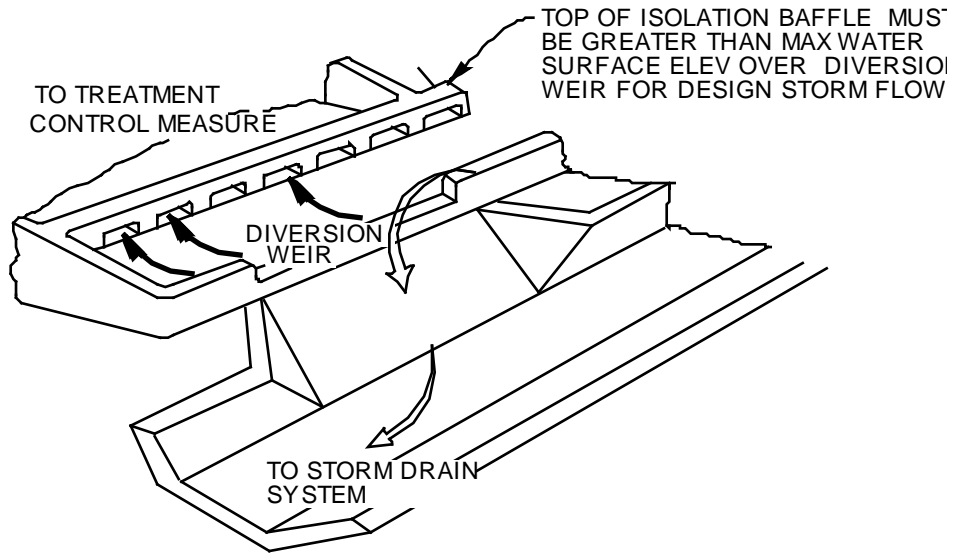

SURFACE CHANNEL DIVERSION STRUCTURE

**Figure H-1. Common Diversion Structures at Inlets**

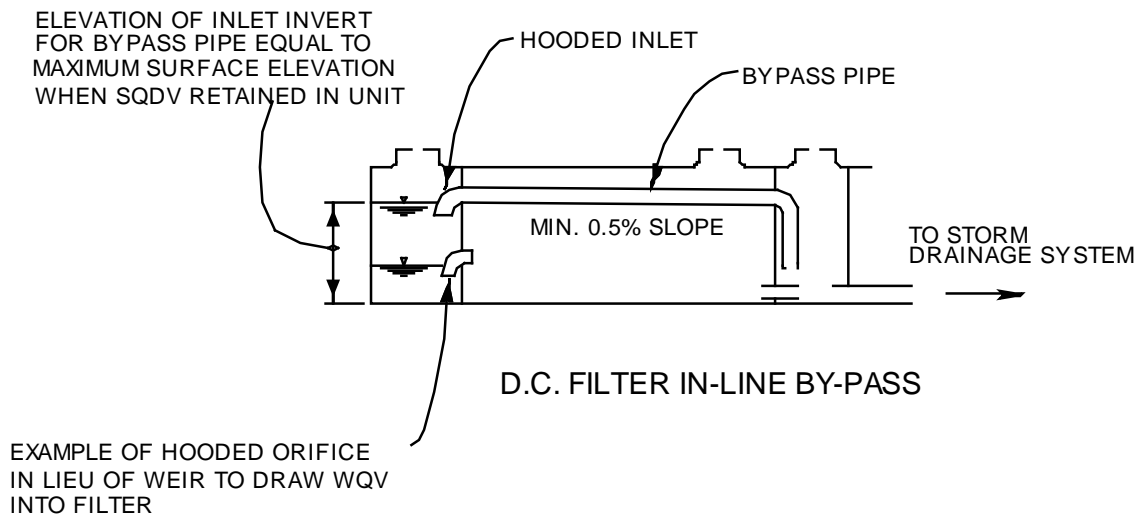

**Figure H-2. Illustration of Pipe Bypass in a Filtration Device**

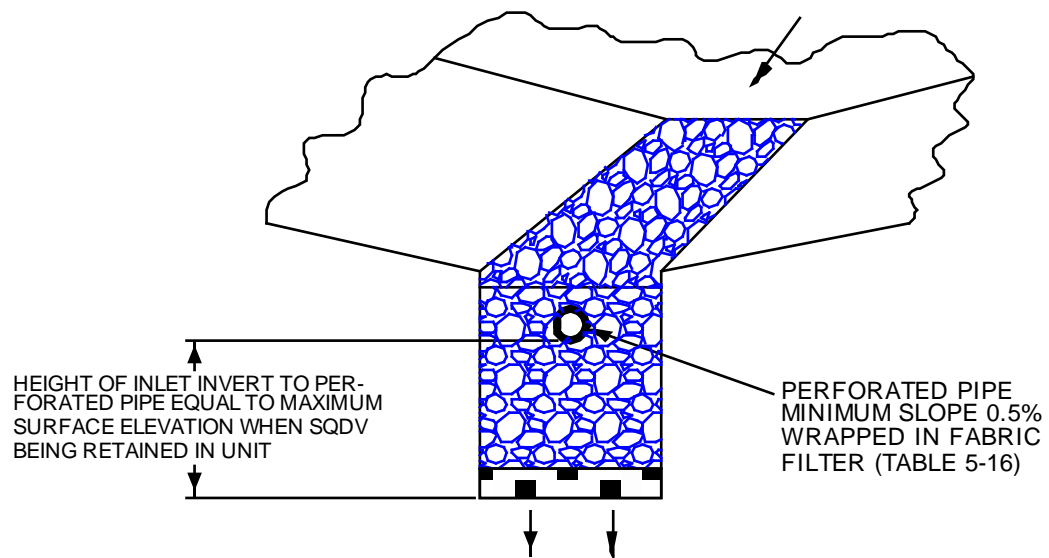

**Figure H-3. Illustration of Pipe Bypass in Infiltration Trench**

**THIS PAGE INTENTIONALLY LEFT BLANK**

---

*Appendix I*

## ***Approved Proprietary Control Measures***

---

This Appendix lists proprietary stormwater treatment devices that have been approved by the City and the County for general use in new development and significant redevelopment projects within the Stockton Urbanized Area. In order to use Proprietary Control Measures, projects must first show that the Volume Reduction Requirement is met through the use of Volume Reduction Measures (Section 5).

To provide a rational basis for approval of proprietary devices, the City and County has elected to recognize as approved for general and pilot use those proprietary devices that have been approved for general, conditional, or pilot use by other selected major stormwater programs that have established and are actively conducting a comprehensive testing protocol and approval process. Currently, the City and County recognizes the lists of proprietary devices approved for general, conditional and pilot use from the following stormwater programs:

- Sacramento Stormwater Quality Partnership (website: <http://www.sacstormwater.org/>)
- State of Washington Department of Ecology (DOE) Stormwater Program (website: <http://www.ecy.wa.gov/programs/wq/stormwater/newtech/index.html>)

The City and County may recognize lists from other programs in the future and will update Appendix J accordingly.

### ***General Use Designation***

The proprietary devices currently approved for general use by the City and County are listed in Table I-1 along with contact information, sizing criteria and basis of approval. This list will be updated periodically when additional proprietary devices are added to the approved list.

**Table I-1. Proprietary Stormwater Treatment Devices Approved for General Use for Basic Treatment by City of Stockton and County of San Joaquin**

<b>Proprietary Device</b>	<b>Manufacturer</b>	<b>Approval Basis</b>	<b>Sizing Criteria</b>
1. StormVault	CONTECH Stormwater Solutions Website: <a href="http://www.contech-cpi.com/stormwater/13">www.contech-cpi.com/stormwater/13</a>	Sacramento Stormwater Quality Partnership general use designation	Water Quality Capture Volume at 6-hour drain time (ASCE Manual and Report on Engineering Practice No. 87)
2. StormFilter	CONTECH Stormwater Solutions Website: <a href="http://www.contech-cpi.com/stormwater/13">www.contech-cpi.com/stormwater/13</a>	Washington DOE general use designation for basic treatment	Stormwater Quality Design Flow (see page 5-6) @ 7.5 gpm /cartridge
3. Media Filtration System (MFS)	CONTECH Stormwater Solutions Website: <a href="http://www.contech-cpi.com/stormwater/13">www.contech-cpi.com/stormwater/13</a>	Washington DOE general use designation for basic treatment	Stormwater Quality Design Flow (see page 5-6) @ 9.0 gpm /cartridge
4. Filterra System	Americast Website: <a href="http://www.filterra.com">www.filterra.com</a>	Washington DOE conditional use designation for basic treatment	Stormwater Quality Design Flow (see page 5-6) @ 50 in/hr infiltration

Any device listed in Table I-1 proposed for use in the Stockton Urbanized Area must be designed, installed, and maintained in accordance with conditions stipulated by the approving program and must include all maintenance, operation, and construction requirements as indicated in Appendix D and as recommended by the manufacturer. Conditional use designations are subject to expiration. Any device proposed for use must have a currently valid use designation by the approving program at the time of approval by the City or County.

### ***Pilot Use Designation***

The proprietary devices currently approved for pilot use by the City and County are listed in Table I-2 along with contact information, sizing criteria and basis of approval. Any device listed in Table I-2 proposed for use in the Stockton Urbanized Area must be designed, installed, and maintained in accordance with conditions stipulated by the approving program and must include all maintenance, operation, and construction requirements as indicated in Appendix D and as recommended by the manufacturer. In addition, if the device is the first of its kind to be installed in the Stockton Urbanized Area, the performance of unit must be monitored in accordance with the performance monitoring protocols stipulated by the approving program.

**Table I-2. Proprietary Stormwater Treatment Devices Approved for Pilot Use for Basic Treatment by City of Stockton and County of San Joaquin**

<b>Proprietary Device</b>	<b>Manufacturer</b>	<b>Approval Basis</b>	<b>Sizing Criteria</b>
1. EcoStorm Plus Stormwater Filtration System	Royal Environmental Systems, Inc Website: <a href="http://www.royalenterprises.net">www.royalenterprises.net</a>	Washington DOE pilot use designation for basic treatment	Stormwater Quality Design Flow (see Section 6) @ 350 gpm/unit
2. Aqua-Filter System	AquaShield, Inc. Website: <a href="http://www.aquashieldinc.com">www.aquashieldinc.com</a>	Washington DOE pilot use designation for basic treatment	Stormwater Quality Design Flow (see Section 6) @ 5.0 gpm/cartridge

Pilot use designations are subject to expiration. Any device proposed for pilot use must have a currently valid use designation by the approving program at the time of approval by the City or County.

### ***Special Cases***

The City and County recognizes that in special cases, typically small in-fill projects, the use of City and County approved basic treatment control measures, either non-proprietary or proprietary, may not be feasible due to physical site constraints. In these special cases, the City or County will consider the use of substitute proprietary pretreatment devices in lieu of approved basic treatment control measures where it can be demonstrated to the satisfaction of the City or County, by means of a thorough engineering analysis, that use of approved general use treatment control measures are not feasible. Proprietary devices that are approved by the City and County as substitute pretreatment devices are listed in Table I-3 along with the sizing criteria and criteria used for approval. This list of approved substitute pretreatment devices will be updated periodically when additional proprietary devices are added to the approved list. Any device listed in Table I-3 proposed for use in the Stockton Urbanized Area must be designed, installed, and maintained in accordance with conditions stipulated by the approving program and must include

all maintenance, operation, and construction requirements as indicated in Appendix D and as recommended by the manufacturer.

**Table I-3. Proprietary Stormwater Treatment Devices Approved as Pretreatment Devices by City of Stockton and County of San Joaquin<sup>1</sup>**

<b>Proprietary Device</b>	<b>Manufacturer</b>	<b>Approval Basis</b>	<b>Sizing Criteria</b>
1. Vortechs System	CONTECH Stormwater Solutions Website: <a href="http://www.contech-cpi.com/stormwater/13">www.contech-cpi.com/stormwater/13</a>	Washington DOE general use designation for pretreatment	Stormwater Quality Design Flow (see page 5-6) or manufacturer's recommendation if greater
2. AquaSwirl System	AquaShield, Inc. Website: <a href="http://www.aquashieldinc.com">www.aquashieldinc.com</a>	Washington DOE general use designation for pretreatment	Stormwater Quality Design Flow (see page 5-6) or manufacturer's recommendation if greater
3. Downstream Defender	Hydro-International Website: <a href="http://www.hydro-international.biz">www.hydro-international.biz</a>	Washington DOE general use designation for pretreatment	Stormwater Quality Design Flow (see page 5-6) or manufacturer's recommendation if greater
4. CDS Stormwater Treatment System	CONTECH Stormwater Solutions Website: <a href="http://www.contech-cpi.com/stormwater/13">www.contech-cpi.com/stormwater/13</a>	Washington DOE general use designation for pretreatment	Stormwater Quality Design Flow (see page 5-6) or manufacturer's recommendation if greater
5. Stormceptor System	Langley Concrete Group Website: <a href="http://www.langleyconcretegroup.com/stormcept2.htm">www.langleyconcretegroup.com/stormcept2.htm</a>	Washington DOE general use designation for pretreatment	

1. Devices considered only in cases where it can be satisfactorily demonstrated that use of approved basic treatment control measures are not feasible.

**THIS PAGE INTENTIONALLY LEFT BLANK**

*Appendix J*  
**Example Calculation**

This Appendix provides an example calculation to illustrate the application of the Volume Reduction Requirement, Volume Reduction Measures, tributary impervious area credit and LID Treatment Controls. The calculation begins at Step 5, Apply Volume Reduction Measures. Real world development applications should also adhere to Steps 1 – 4 as described in Section 2.

**SITE CONDITIONS**

A commercial site design (**Figure J-1**), is used for the example calculation. This is a new development scenario and it is assumed that the pre-project conditions primarily consisted of disturbed soils with some undisturbed open space and no impervious cover elements.

**STEP 5: APPLY VOLUME REDUCTION MEASURES**

The substeps for Step 5 as described in Section 5 are as follows:

- Calculate the Volume Reduction Requirement (post - pre)
- Select Volume Reduction Measures
- Determine volume reduction
- Determine remaining Volume Reduction Requirement
- Determine tributary impervious area credits

**Calculate Volume Reduction Requirement**

***Pre-Project Volume***

Site element	Element Area ft <sup>2</sup>	Fraction of Total Area	Runoff Coefficient	Weighted Runoff Coefficient <small>(Fraction of Total Area * Runoff Coefficient)</small>	0.51-inch Storm Volume, ft <sup>3</sup> <small>(Total Project Area * Total Weighted Runoff Coefficient)</small>
Disturbed soils	76,750	0.91	0.25	0.23	
Undisturbed open space /trees	7,250	0.09	0.05	0.00	
Total	84,000			<b>0.23</b>	<b>831</b>

### Post-Project Volume

Site element	Element Area ft <sup>2</sup>	Fraction of Total Area	Runoff Coefficient	Weighted Runoff Coefficient (Fraction of Total Area * Runoff Coefficient)	0.51-inch Storm Volume, ft <sup>3</sup> (Total Project Area * Total Weighted Runoff Coefficient)
Permeable pavers	2,410	0.03	0.60	0.02	
Roofs	15,200	0.18	0.95	0.17	
Parking lot	22,961	0.27	0.95	0.26	
Driveway	14,531	0.17	0.95	0.16	
Plaza	4,755	0.06	0.95	0.05	
Walkways	5,607	0.07	0.95	0.06	
Amended soils	11,286	0.13	0.05	0.01	
Undisturbed open space /trees	7,250	0.09	0.05	0.00	
Total	84,000			0.74	<b>2,647</b>
Pre-project Volume					831
<b>Volume Reduction Requirement (post – pre)</b>					<b>1,816</b>

### Select Volume Reduction Measures & Determine Volume Reduction

Thirty-four evergreen, interception trees were selected as the Volume Reduction Measures for this site. Additional details on interception trees can be found in Fact Sheet V-4.

Parameter	Unit	Value
No. of trees	ea	34
Avg. canopy diameter	ft	20
Unit projected canopy area (area of tree projected over impervious area)	ft <sup>2</sup>	314
Total canopy area (unit projected canopy area * no. of trees)	ft <sup>2</sup>	10,676
Percent interception	%	40%
<b>Volume reduction</b> (0.51" * Total canopy area * Percent interception / 12 in/ft)	ft <sup>3</sup>	<b>181</b>

### Determine Remaining Volume Reduction Requirement

Remaining Volume Reduction Requirement (Volume Reduction Requirement – Interception Tree Volume Reduction):  
 $1,816 \text{ ft}^3 - 181 \text{ ft}^3 = 1,635 \text{ ft}^3$

### Determine Tributary Impervious Area Credits

Each Volume Reduction Measure fact sheet describes how impervious area credits are calculated. See Fact Sheet V-4 for details on calculating the credits associated with interception trees.

Site Element	Area of Canopy Coverage ft <sup>2</sup>	Impervious Area Credit ft <sup>2</sup> (Area of Canopy Coverage * Percent Interception)
Parking lot	5,018	2,007
Plazas	3,737	1,495
Walkways	1,921	768
Total	10,676	4,270

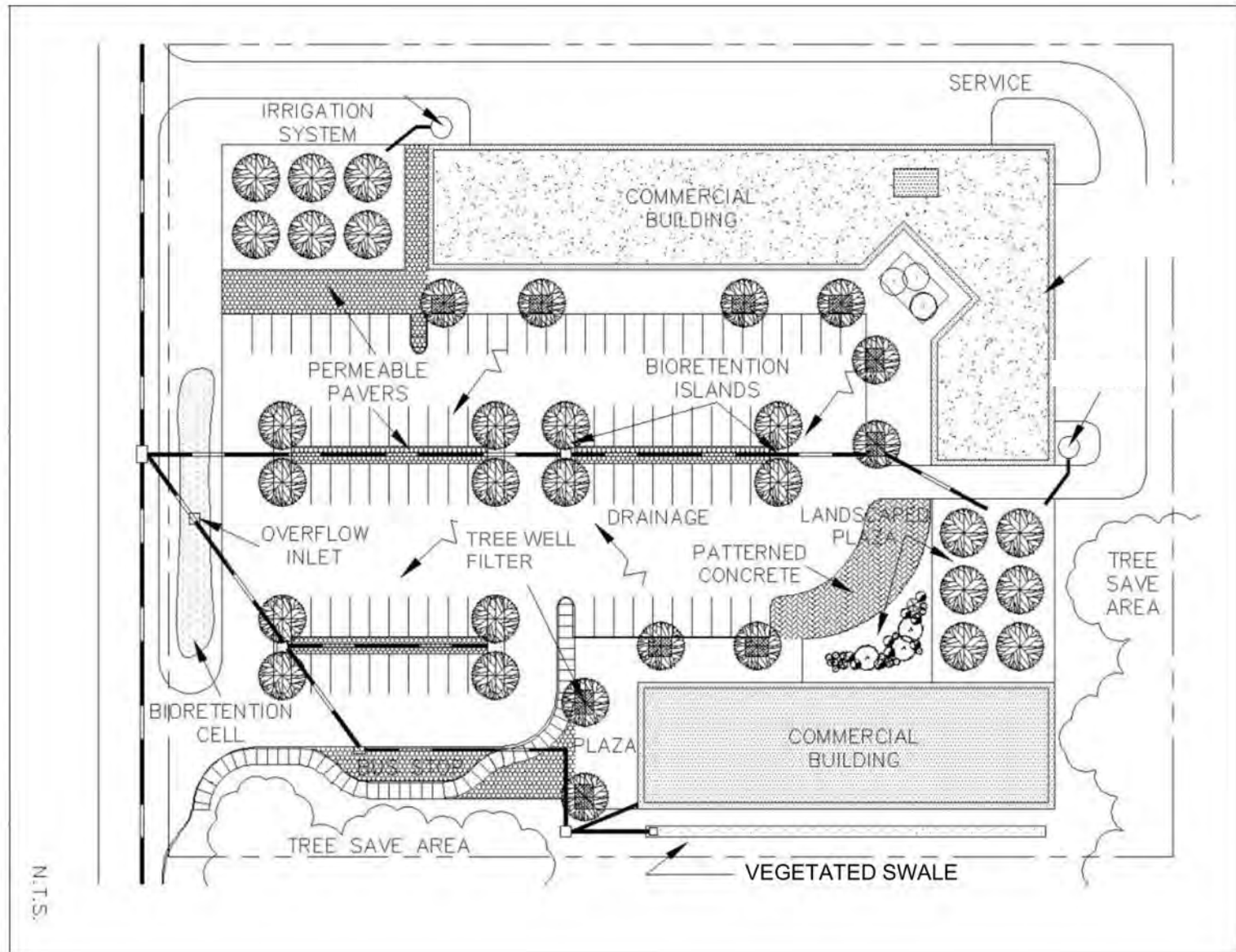

Figure J-1. Example Commercial Site Design (modified from LID Center)

## STEP 6: APPLY LID TREATMENT CONTROLS

If Volume Reduction Requirement was not met through use of Volume Reduction Measures (Step 5), LID Treatment Controls must be used to further reduce volume. Treatment controls must be designed to treat the SQDF or SQDV.

In this example calculation, the Volume Reduction Requirement was not fully met through the use of Interception Trees as a result, the development will also apply the following LID Treatment Controls:

- Parking Lot Bioretention
- Vegetated Swale
- Bioretention Cell
- Tree-well Filter

Calculations for each of the LID Treatment Controls are provided in the tables below.

<b>Parking Lot Bioretention</b>	<b>Unit</b>	<b>Value</b>
Tributary area (Area draining to parking lot bioretention)	ft <sup>2</sup>	22,961
Tributary impervious area credit (see Tributary Impervious Area Credits in Step 5)	ft <sup>2</sup>	2,007
Effective tributary area (Tributary area – Tributary impervious area credit)	ft <sup>2</sup>	20,954
SQDV <sup>1</sup> (Unit Basin Storage Volume <sup>2</sup> * Effective tributary area * 1ft/12in)	ft <sup>3</sup>	559
Bioretention area	ft <sup>2</sup>	1,563
Depth of ponding zone	ft	0.50
Depth of planting zone	ft	1.50
Treatment volume provided <sup>1</sup> (Bioretention area * Depth of ponding zone)	ft <sup>3</sup>	782
<b>Volume reduction</b> (Depth of ponding zone * Bioretention area * 0.25) + (Depth of planting zone * Bioretention area * 0.1)	ft <sup>3</sup>	430
1: SQDV is treatment volume required; Treatment volume provided is the amount of treatment actually provided by parking lot bioretention 2: See Figure 6-1		

<b>Vegetated Swale</b>	<b>Unit</b>	<b>Value</b>
Tributary area (Area draining to vegetated swale)	ft <sup>2</sup>	5,188
Tributary impervious area credit (see Tributary Impervious Area Credits in Step 5)	ft <sup>2</sup>	-
Effective tributary area (Tributary area – Tributary impervious area credit)	ft <sup>2</sup>	5,188
SQDV <sup>1</sup> (Unit Basin Storage Volume <sup>2</sup> * Effective tributary area * 1ft/12in)	ft <sup>3</sup>	138
Swale area	ft <sup>2</sup>	798
Depth of ponding zone	ft	0.67
Depth of planting zone	ft	1.50
Treatment volume provided <sup>1</sup> (Swale area * Depth of ponding zone)	ft <sup>3</sup>	535
<b>Volume reduction</b> (Depth of ponding zone * Swale area * 0.25) + (Depth of planting zone * Swale area * 0.1)	ft <sup>3</sup>	253
1: SQDV is treatment volume required; Treatment volume provided is the amount of treatment actually provided by vegetated swale 2: See Figure 6-1		

<b>Bioretention Cell</b>	<b>Unit</b>	<b>Value</b>
Tributary area (Area draining to bioretention cell)	ft <sup>2</sup>	32,560
Tributary impervious area credit (see Tributary Impervious Area Credits in Step 5)	ft <sup>2</sup>	768
Effective tributary area (Tributary area – Tributary impervious area credit)	ft <sup>2</sup>	31,792
SQDV <sup>1</sup> (Unit Basin Storage Volume <sup>2</sup> * Effective tributary area * 1ft/12in)	ft <sup>3</sup>	848
Bioretention area	ft <sup>2</sup>	2,272
Depth of ponding zone	ft	1.00
Depth of planting zone	ft	1.50
Treatment volume provided <sup>1</sup> (Bioretention area * Depth of ponding zone)	ft <sup>3</sup>	2,272
<b>Volume reduction</b> (Depth of ponding zone * Bioretention area * 0.25) + (Depth of planting zone * Bioretention area * 0.1)	<b>ft<sup>3</sup></b>	<b>909</b>
1: SQDV is treatment volume required; Treatment volume provided is the amount of treatment actually provided by bioretention cell 2: See Figure 6-1		

<b>Tree-well Filters</b>	<b>Unit</b>	<b>Value</b>
Tributary area (Area draining to tree-well filter)	ft <sup>2</sup>	4,755
Tributary impervious area credit (see Tributary Impervious Area Credits in Step 5)	ft <sup>2</sup>	1,495
Effective tributary area (Tributary area – Tributary impervious area credit)	ft <sup>2</sup>	3,260
SQDV <sup>1</sup> (Unit Basin Storage Volume <sup>2</sup> * Effective tributary area * 1ft/12in)	ft <sup>3</sup>	87
No. of filters	ea	12
Unit filter area	ft <sup>2</sup>	16
Total filter area (No. of filters * Unit filter area)	ft <sup>2</sup>	192
Depth of ponding zone	ft	0.75
Depth of planting zone	ft	1.50
Treatment volume provided <sup>1</sup> (Total filter area * Depth of ponding zone)	ft <sup>3</sup>	144
<b>Volume reduction</b> (Depth of ponding zone * Total filter area * 0.25) + (Depth of planting zone * Total filter area * 0.1)	<b>ft<sup>3</sup></b>	<b>65</b>
1: SQDV is treatment volume required; Treatment volume provided is the amount of treatment actually provided by bioretention cell 2: See Figure 6-1		

## SUMMARY OF VOLUME REDUCTION

<b>Control Measure</b>	<b>Units</b>	<b>Volume Reduction</b>
Tree Interception	ft <sup>3</sup>	181
Parking Lot Bioretention	ft <sup>3</sup>	430
Vegetated Swale	ft <sup>3</sup>	253
Bioretention Cell	ft <sup>3</sup>	909
Tree-well Filters	ft <sup>3</sup>	65
<b>Total Volume Reduction</b>	<b>ft<sup>3</sup></b>	<b>1,838</b>
<b>Volume Reduction Requirement</b>	<b>ft<sup>3</sup></b>	<b>1,816</b>

**THIS PAGE INTENTIONALLY LEFT BLANK**

- Alameda Countywide Clean Water Program October 1996. Final Monitoring Report, Grassed Swales at the ADVO Facility, Newark, prepared by Woodward-Clyde Consultants.
- Association of Bay Area Governments May 1995. Manual of Standards for Erosion and Sediment Control Measures, Second Edition.
- Bay Area Stormwater Management Agencies Association (BASMAA), 1999. Start at the Source, Design Guidance for Stormwater Quality Protection.
- California Stormwater Quality Task Force, March 1993. California Storm Water Industrial/Commercial Best Management Practice Handbook, prepared by Camp Dresser & McKee, Larry Walker Associates, Uribe and Associates, Resource Planning Associates.
- California Stormwater Quality Association, January 2003. California Stormwater Best Management Practices Handbooks, prepared for by Camp Dresser & McKee, Larry Walker Associates, et.al.
- Center for Watershed Protection (CWP). 2003. Impacts of Impervious Cover on Aquatic Systems. Ellicott City, MD.
- Center for Watershed Protection (CWP). 2007. Urban Stormwater Retrofit Practices. Manual 3 of the Urban Subwatershed Restoration Manual Series. Ellicott City, MD.
- Chow, Ph.D., V.T., 1959. Open-Channel Hydraulics, McGraw-Hill, Inc., New York.
- City of Alexandria Department of Transportation and Environmental Services 1992. Assessment of the Pollutant Removal Efficiencies of Delaware Sand Filters BMPs.
- City of Alexandria Department of Transportation and Environmental Services, February 1992. Supplement to the Northern Virginia BMP Handbook.
- City of Austin, 1991. Environmental Binder, Section 1, Water Quality Management.
- City of Modesto, Operations and Maintenance Department, January 2001. Guidance Manual for New Development Stormwater Quality Control Measures.
- City of Portland. 2008. Stormwater Management Manual. Portland, OR.
- City of Sacramento Department of Utilities and County of Sacramento Water Resources Division, January 2000. Guidance Manual for On-Site Stormwater Quality Control Measures.

- County of San Diego. 2007. Low Impact Development Handbook. Department of Planning and Land Use. San Diego, CA.
- Denver Colorado Urban Drainage and Flood Control District (UDFCD), 1999. Urban Drainage Criteria Manual, Volume 3 – Best Management Practices Stormwater Quality.
- Denver Colorado Urban Drainage and Flood Control District(UDFCD), 1992. Urban Drainage Criteria Manual, Volume 3 – Best Management Practices Stormwater Quality.
- Federal Highway Administration, August 1989. Retention, Detention, and Overland Flow for Pollutant Removal from Highway Stormwater Runoff, Volume II Design Guidelines, Draft, Report No. FHWA/RD-89/203.
- Federal Interagency Stream Restoration Working Group (FISRWG). 1998. "Stream Corridor Restoration: Principles, Processes, and Practices." Federal Interagency Stream Restoration Working Group (FISRWG). GPO Item No. 0120-A; SuDocs No. A 57.6/2:EN 3/PT.653. ISBN-0-934213-59-3.
- Goldman S.J., Jackson K., Bursztynsky, P.E., T.A., 1986. Erosion and Sediment Control Handbook, McGraw-Hill Inc., New York.
- Haltiner J. 2006. Hydrograph Modification: An Introduction and Overview. Philip Williams & Associates. Powerpoint Presentation.
- Metropolitan Washington Council of Governments, March 1992. A Current Assessment of Urban Best Management Practices, Techniques for Reducing Non-Point Source Pollution in the Coastal Zone.
- North Carolina 1993. Storm Water Management Guidance Manual, North Carolina.
- Northern Virginia Planning District, Engineers and Surveyors Institute, January 1996, Northern Virginia BMP Handbook Addendum, Sand Filtration Systems.
- Puget Sound Action Team & Washington State University Pierce County Extension. 2005. Low Impact Development: Technical Guidance Manual for the Puget Sound.
- Retail Gasoline Outlet Work Group, March 1997. Best Management Practice Guidelines Retail Gasoline Outlets.
- Roesner L., Urbonas B., Sonnen M., July 1988. Design of Urban Runoff Quality Controls, American Society of Civil Engineers, New York.
- Schueler, T.R. July 1987. Controlling Urban Runoff: A Practical Manual for Planning and Designing Urban BMPs, Metropolitan Washington Council of Governments, Department of Environmental Programs.

- Seattle Engineering Department Drainage and Wastewater Utility 1993. Dayton Avenue W. Swale Biofiltration Study.
- U.S. Environmental Protection Agency (EPA). 2007. Reducing Stormwater Costs through Low Impact Development (LID) Strategies and Practices. EPA 841-F-07-006.
- U.S. EPA. 1993. Guidance Specifying Management Measures for Sources of Nonpoint Pollution in Coastal Waters, Chapter 4. EPA 840-B-92-002.
- U.S. EPA. 1993. Handbook Urban Runoff Pollution Prevention and Control Planning, EPA/625/R-93/004.
- U.S. EPA. 1992. Storm Water Management for Industrial Activities, Developing Pollution Prevention Plans and Best Management Practices, EPA 832-R-92-006.
- Uribe & Associates, Larry Walker Associates, October 1994. Action Plan Demonstration Project, Demonstration of Gasoline Fueling Station BMPs, prepared for US EPA Region IX.
- Ventura County Flood Control and Water Resources Department, 1991. Hydrology Manual.
- Washington State Department of Ecology, October 1992. Biofiltration Swale Performance, Recommendations, and Design Considerations, Publication 657, Grant Tax. No. 89-136.
- Water Environment Federation and American Society of Civil Engineers 1992. Design and Construction of Urban Stormwater Management Systems.
- Watershed Management Institute, Inc., August 1997. Operation, Maintenance and Management of Stormwater Management Systems.
- Woodward-Clyde Memorandum June 1995 to City of Fresno Metropolitan Flood Control District, Vegetated Swale Guidelines.

**THIS PAGE INTENTIONALLY LEFT BLANK**